



MODEL XL-75

★ UNDER FLOOR

FOR UP TO 75" TV

- Lift Extends 162.6 cm Upwards
- TV Maximum Screen Size: 75"
- Maximum Weight: 59 kg

Model XL-75 combines unparalleled performance with maximum extension. Multiple telescoping lift columns work in unison to provide an incredible 162.6 cm of vertical travel. This mechanism enables you to smoothly raise up to a 75" television from beneath the floor to a proper viewing height, transforming any room into a home theatre in just 25 seconds.

- Near Silent Operation
- Extra-Long Extension
- Remote Control Included
- Popular for Under Floor Applications in Any Room



All Nexus products are shipped in custom-made protective packaging, and they include everything you need to mount and operate them. The products are designed for easy assembly and simple instructions with photos are included.

MODEL XL-75



TECHNICAL SPECIFICATIONS

- 59 kg total lift capacity
- TV maximum screen size: 75"
- Travels 162.6 cm
- No exposed tracks, gears or scissors
- UL recognized components
- Draws 3.5 Amps @ 110V and 1.75 Amps @ 220V at max thrust
- Speed 6.4 cm /sec. (only 25 seconds to fully raise)
- Quiet - runs at just 45 dB
- Screw-driven mechanism
- Steel construction
- Your choice of RF remote or Control System Integration Kit (CSI Kit includes IR remote and contact closure interface)
- Exclusive Nexus 21 Safety Package included
- "Soft Start" and "Soft Stop" for smooth ride
- Power is Available in These Formats:
USA, 110V / Europe, 230V / Japan, 100V
Australia, 240V / UK, 230V

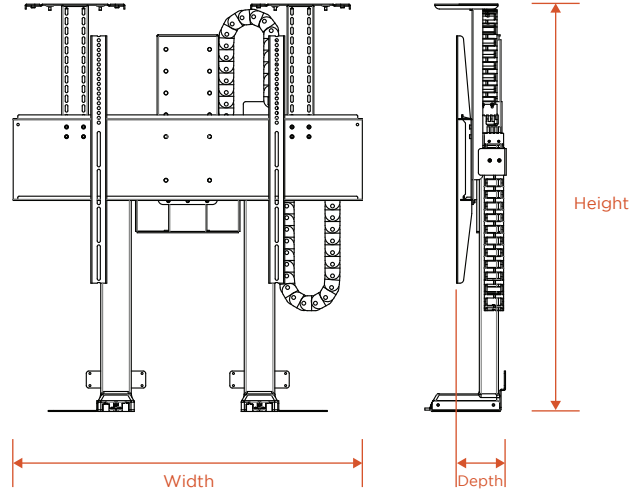

Height: 106.7 cm Min / 136.5 cm Max
Width: 91.4 cm
Depth: 13 cm from back wall to rear of TV

WHAT'S IN THE BOX

- Motorized lift columns (the motorized units are pre-assembled and ready to use)
- Heavy duty screen support with universal TV mounting plate
- Height adjustable top supports
- Top plate with adjustable extensions and finger safety
- Upper and lower rear mounting brackets
- Control box with power cord
- Motorized lift column motor cables
- Remote control and receiver (your choice of RF or CSI Kit*)
- Backup control switch
- Cable management tracks
- All hardware for assembly and mounting
- Full assembly instructions with photos



CONTROL OPTIONS

Your choice of RF remote or Control System Integration Kit (CSI Kit*). Wired button pad included with both.

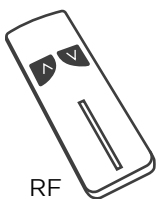

or



Button Pad

*CSI Kit includes IR remote and contact closure interface

COMPATIBLE LID STYLES

Mounting bracket for floating lid included (our standard option) or purchase guides for a hinged lid version. Built-in finger safety system included.

