

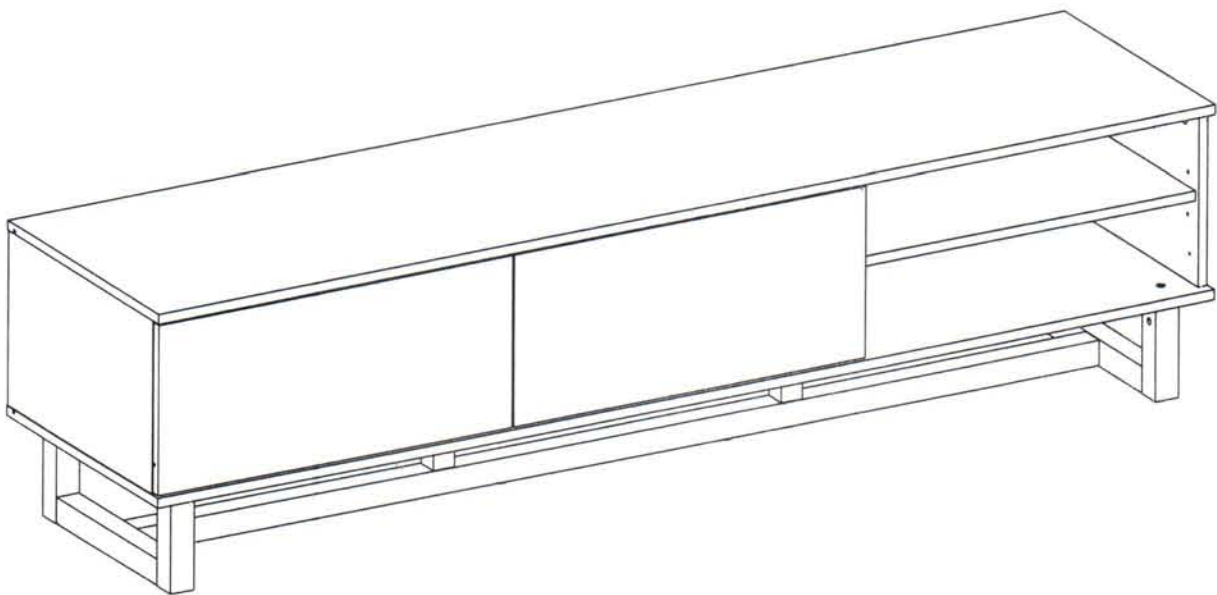

ASSEMBLY INSTRUCTIONS

RZ1500WO

RAZE SERIES MODULAR AV CABINET



Thank you for choosing AVS RZ1500WO AV Furniture. Before beginning assembly, please check all parts are included and undamaged. For any assembly or parts enquiries, please contact AV Supply Group Ltd on (09) 2749172 or email to info@avsupply.co.nz

" IMPORTANT: Please Choose your preferred configuration BEFORE installing draws & shelves "

" IMPORTANT: REMOVE protective plastic film from panels BEFORE assembling the cabinet "

RZ1500WO

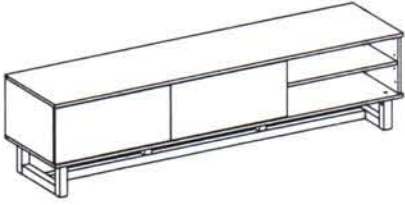

The cabinet top supports up to 55 kg (121 lbs.)
 The each drawer supports up to 10 kg (22 lbs.)
 The shelf supports up to 5 kg (11 lbs.)

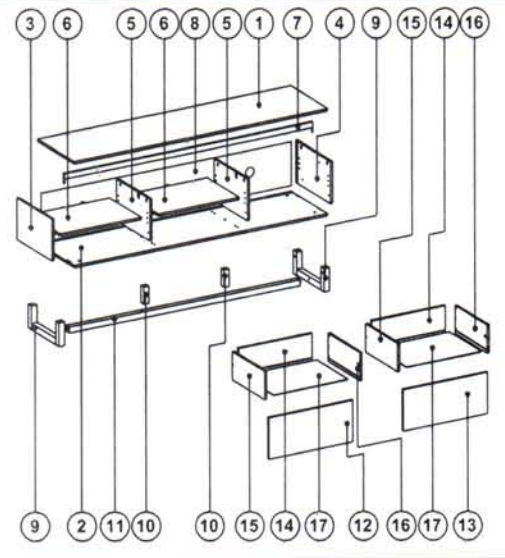
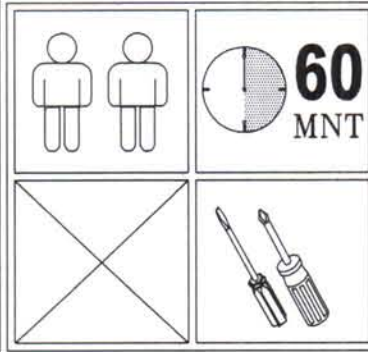

PRODUCT CARE: Care for your furniture by cleaning with glass cleaner and a disposable paper towel, do NOT use abrasive chemical products to clean your AVS furniture

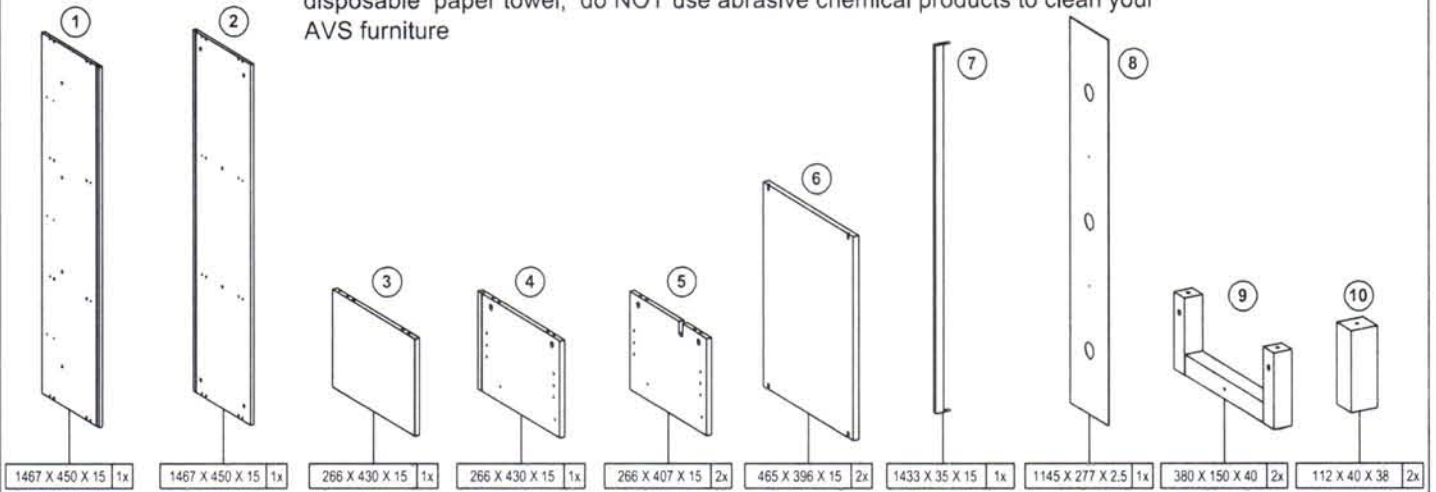

CAUTION: Do not use this product for any purpose not explicitly specified by AVS. Improper installation may cause property damage or personal injury. If you do not understand these directions, or have doubts about the safety of the installation, contact AVS Customer Service or call a qualified contractor. Arisit is not responsible for damage or injury caused by incorrect mounting, assembly, or use.

WARNING! This product contains small items that could be a choking hazard if swallowed. Keep these items away from young children!

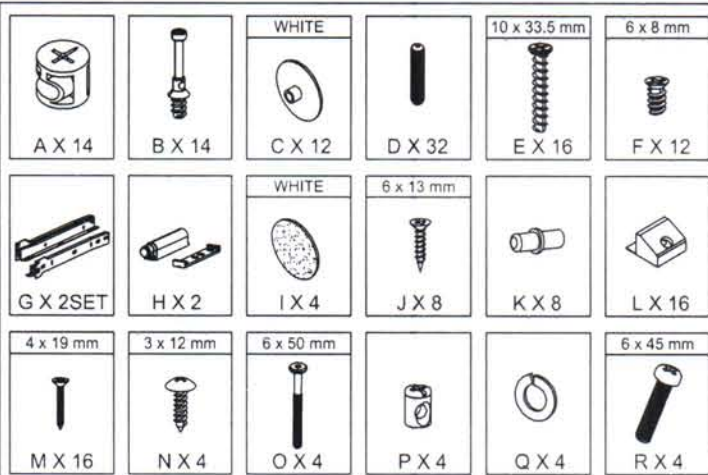
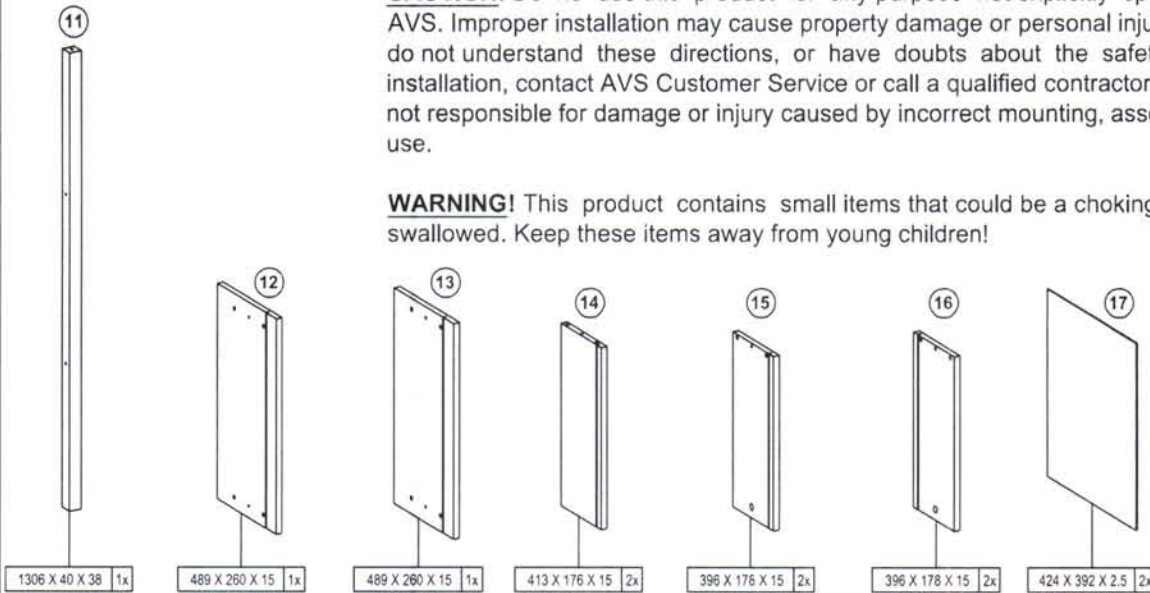

AV Supply Group (AVS) intends to make this manual accurate and complete. However, AVS makes no claim that the information contained herein covers all details, conditions, or variations. Nor does it provide for every possible contingency in connection with the installation or use of this product. The information contained in this document is subject to change without notice or obligation of any kind. AVS makes no representation of warranty, expressed or implied, regarding the information contained herein. AVS assumes no responsibility for accuracy, completeness or sufficiency of the information contained in this document.

RZ1500WO

1

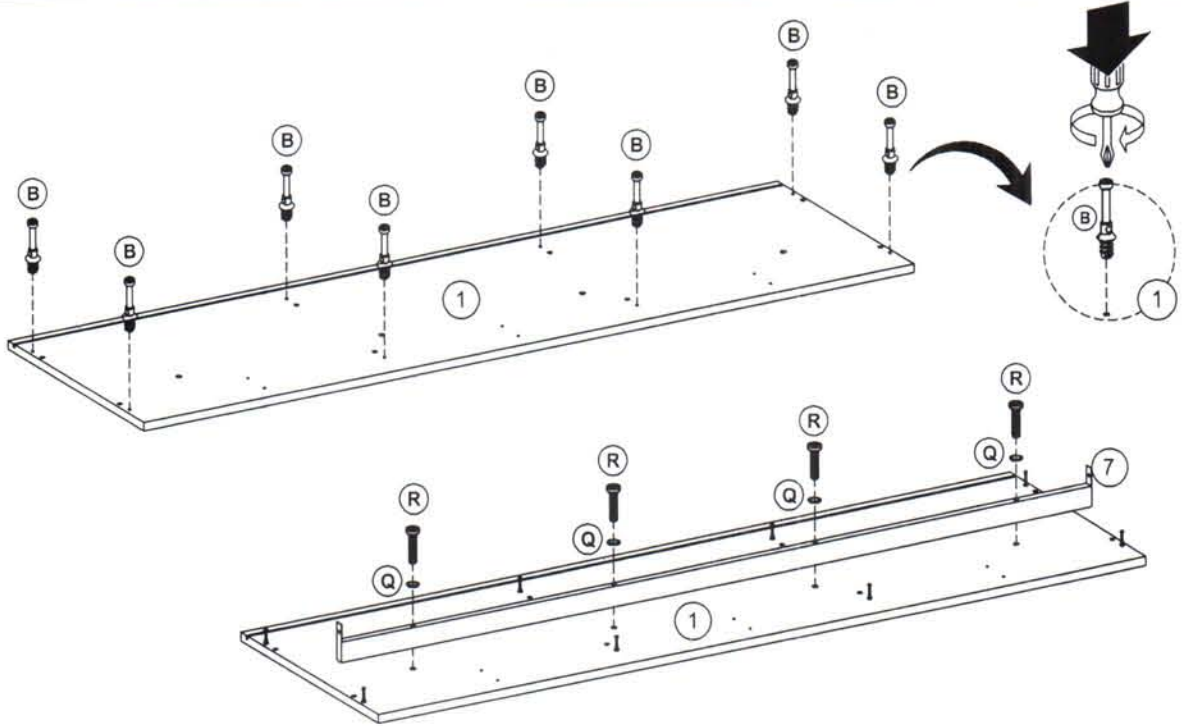

2

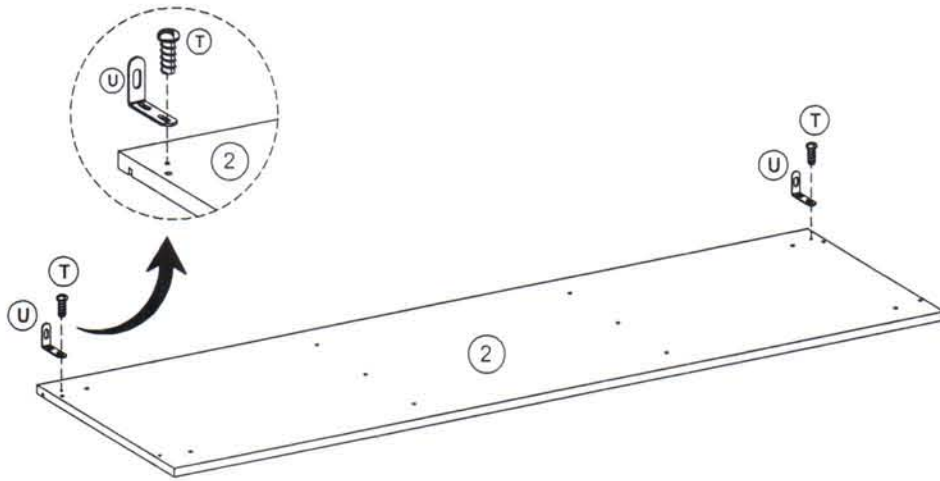

3

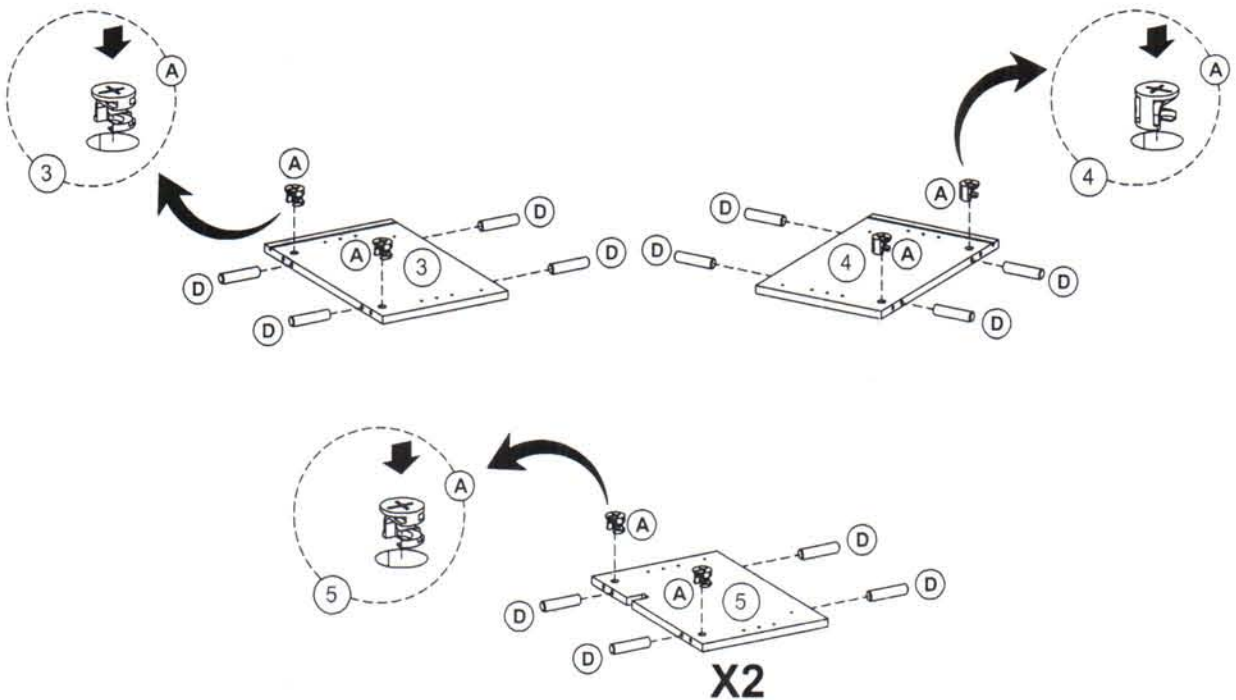

RZ1500WO

4

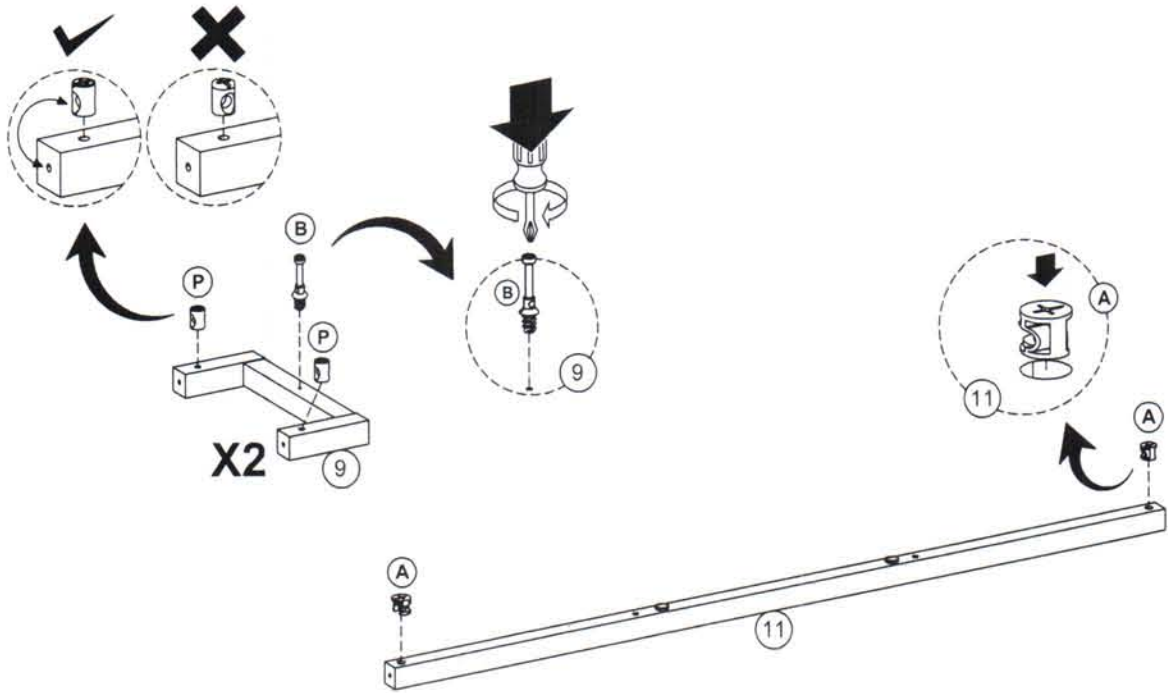

5

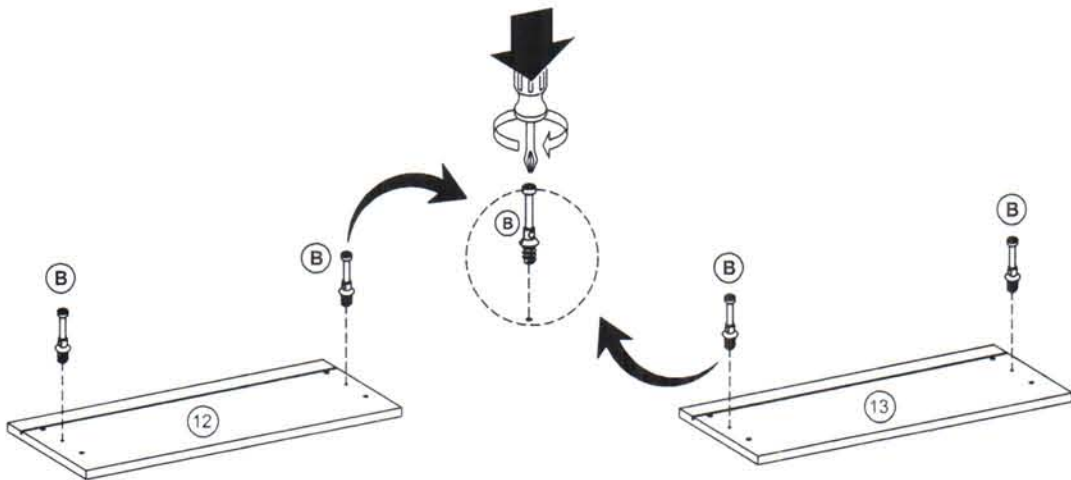

6

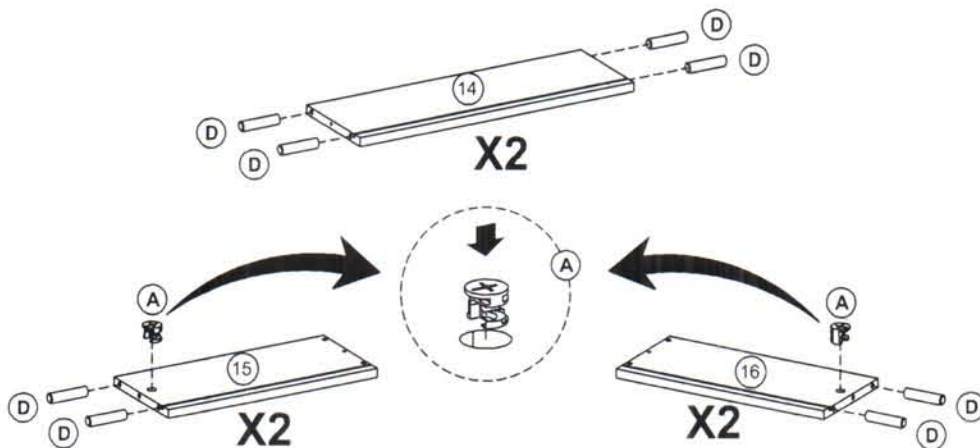

RZ1500WO

7

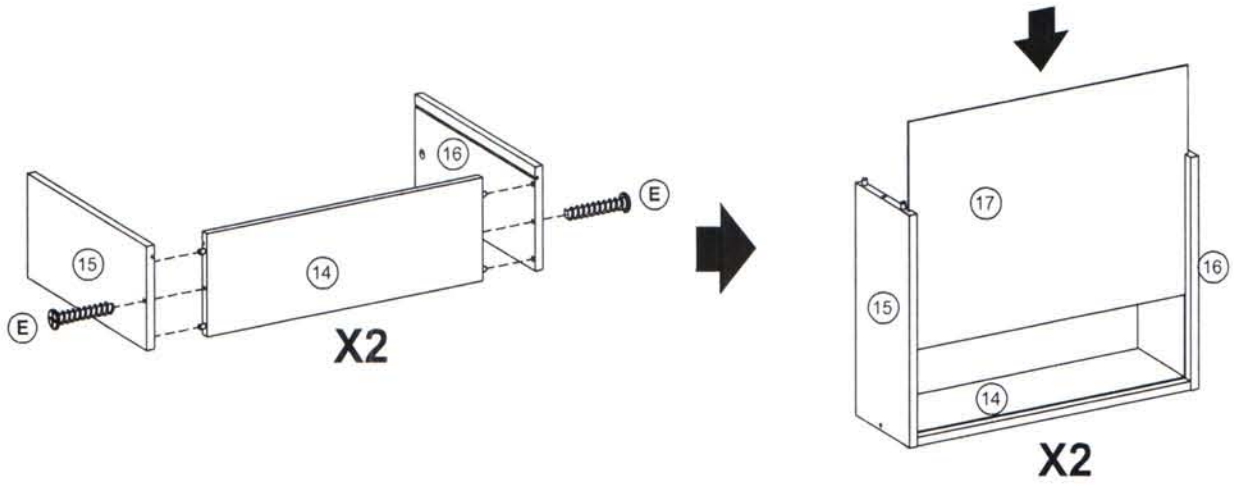

8

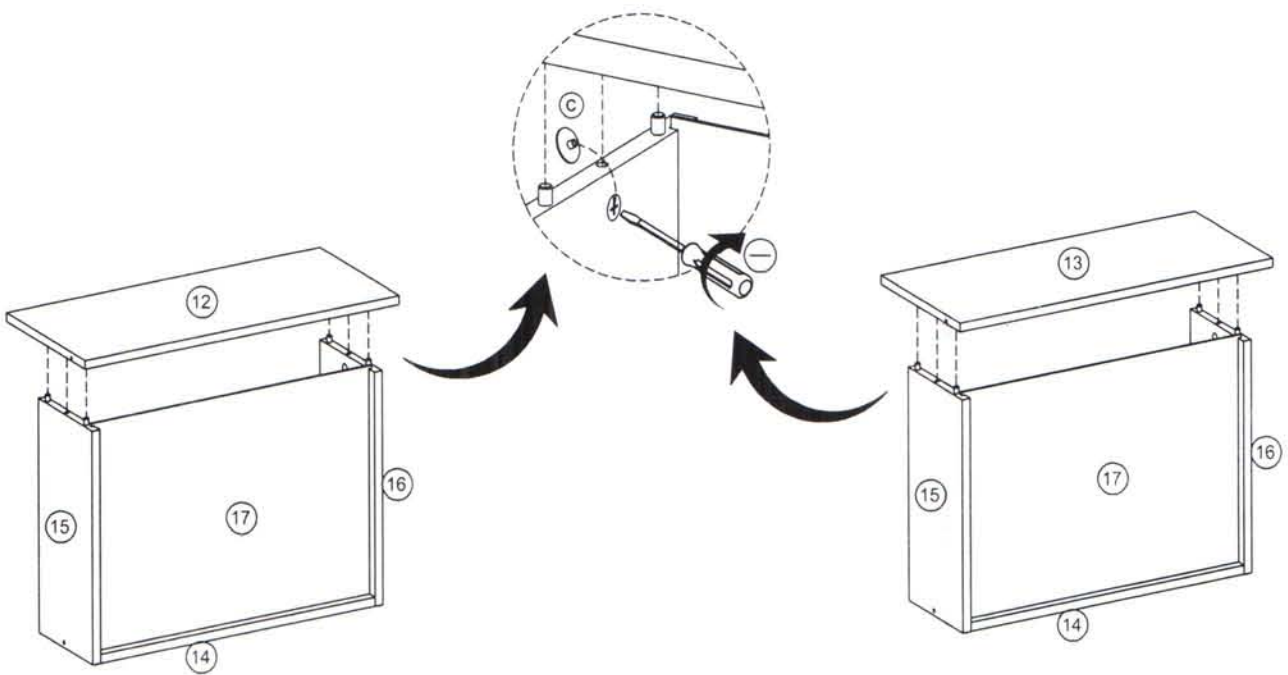

RZ1500WO

9

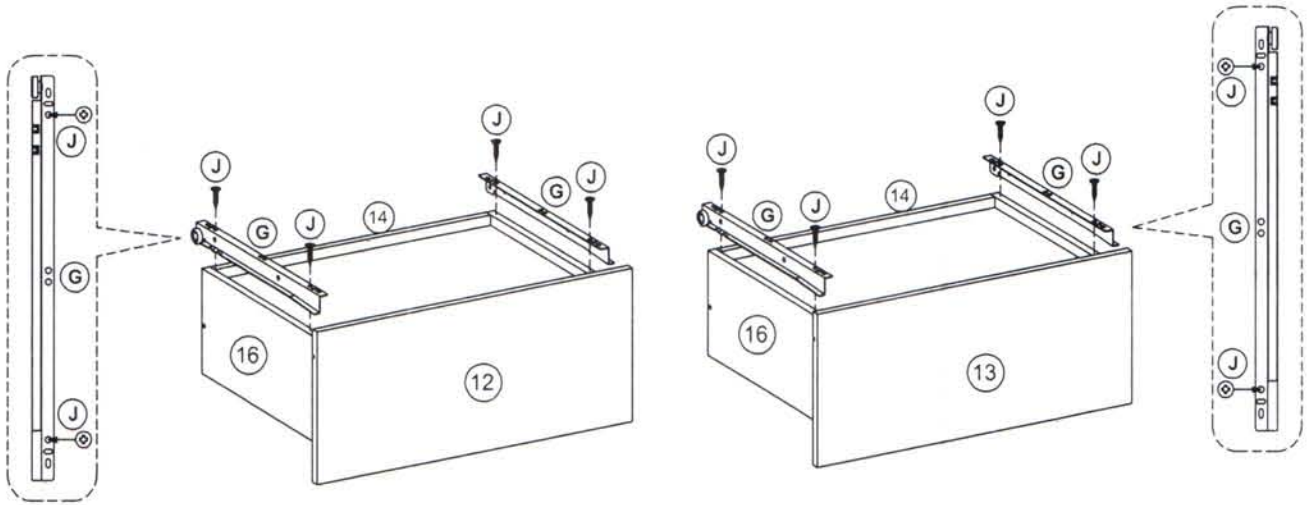

10

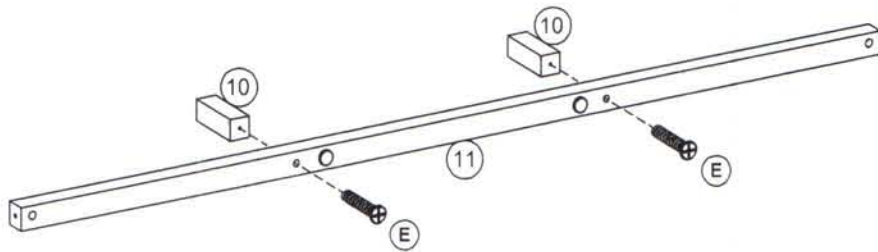

11

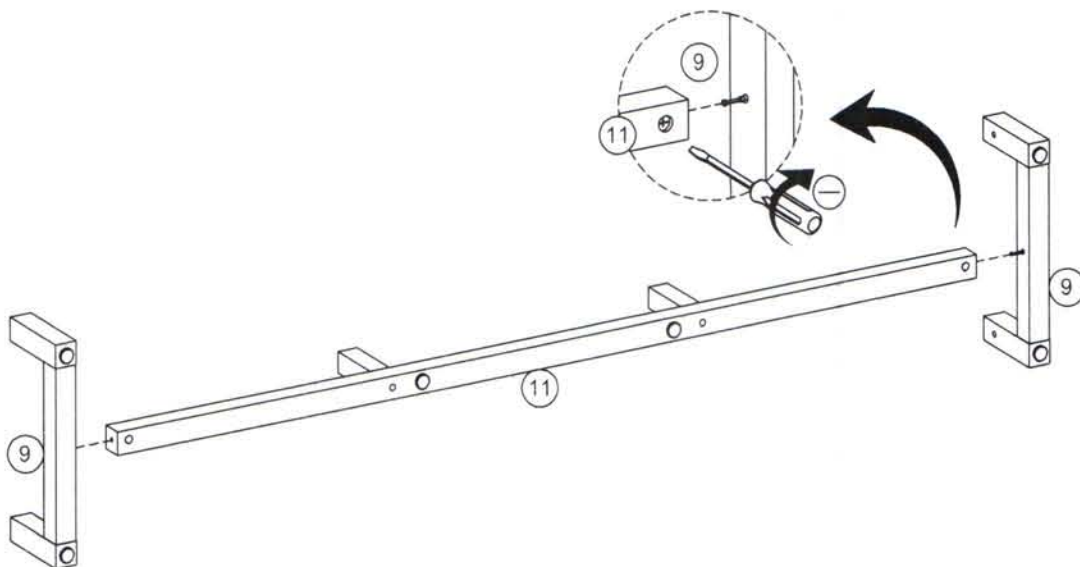

RZ1500WO

12

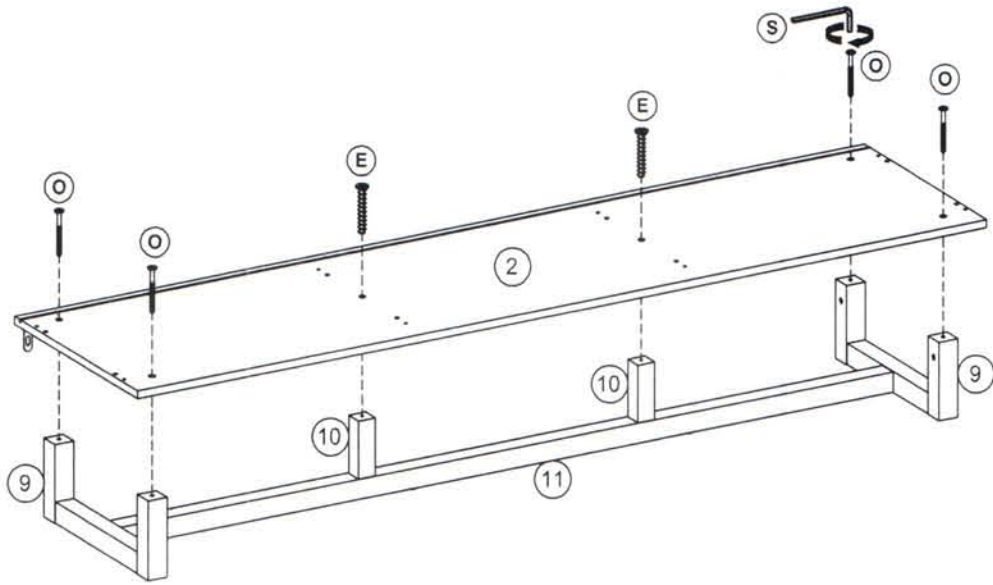

13

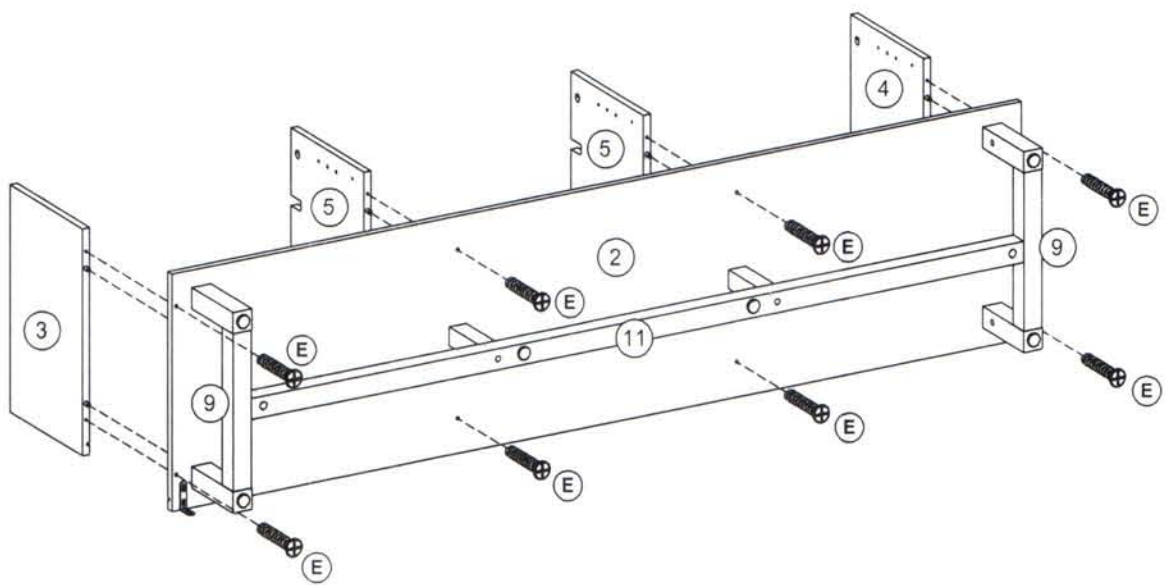

RZ1500WO

14

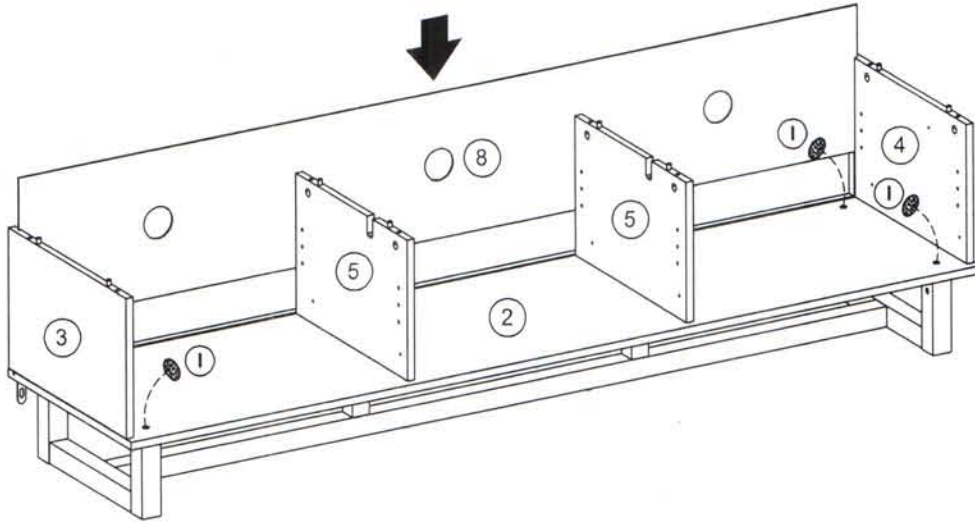

15

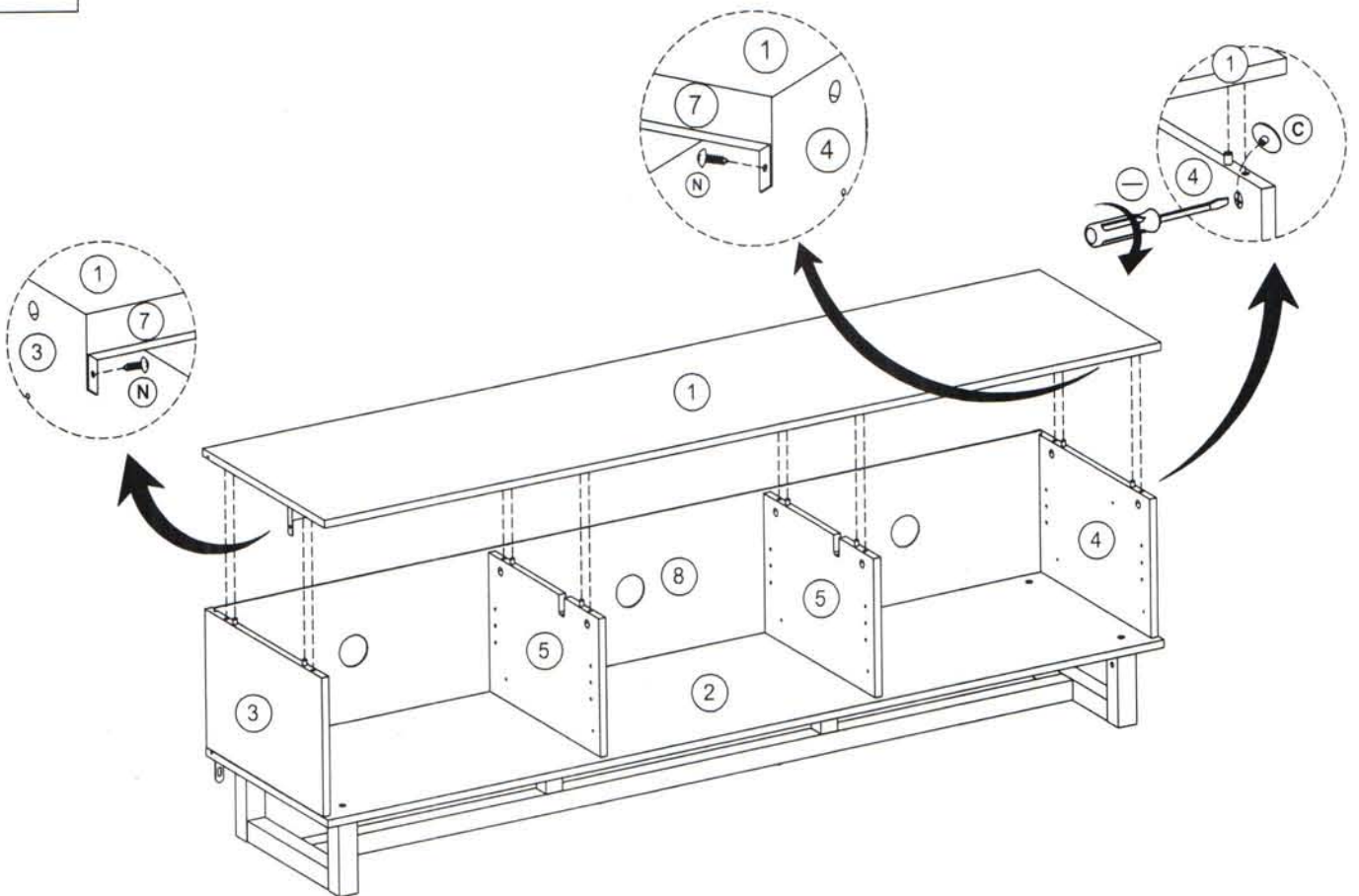

RZ1500WO

16

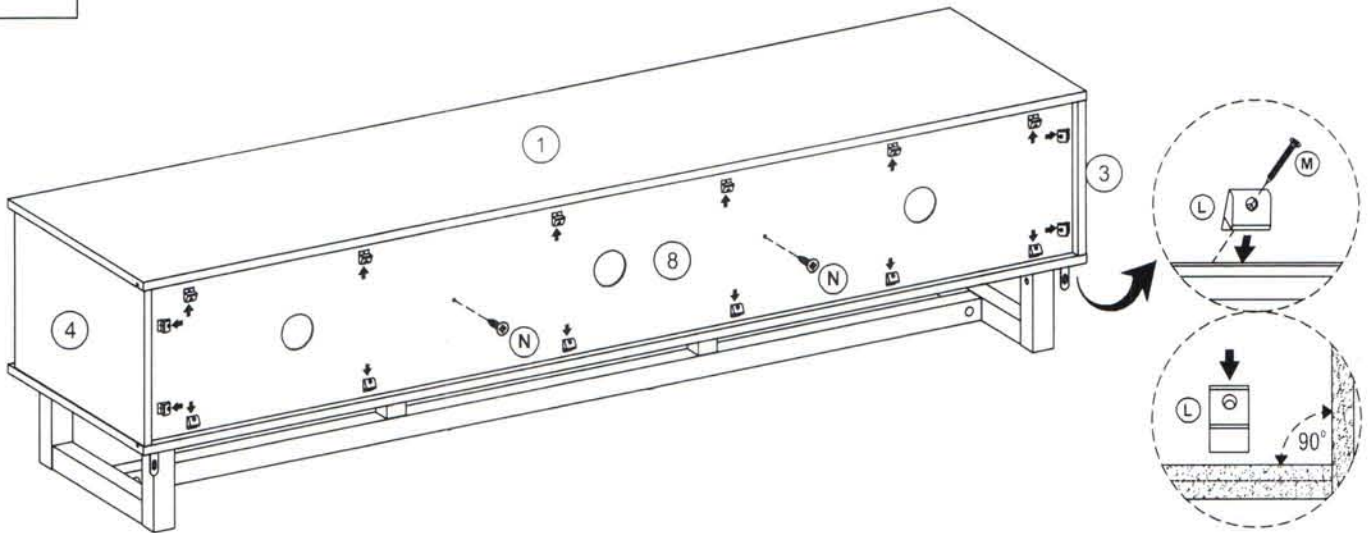

OPTIONAL FOR ASSEMBLY DRAWER & SHELF

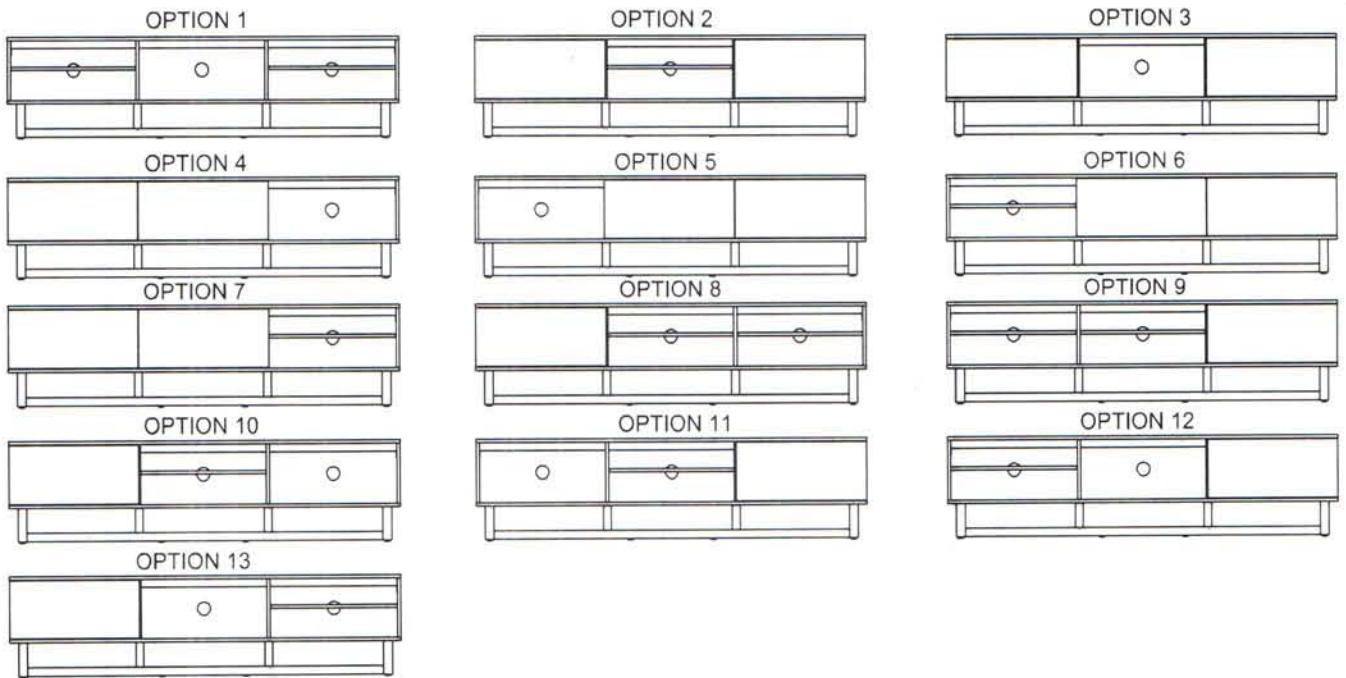

17

OPTION 1

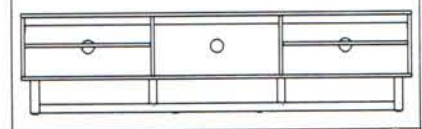
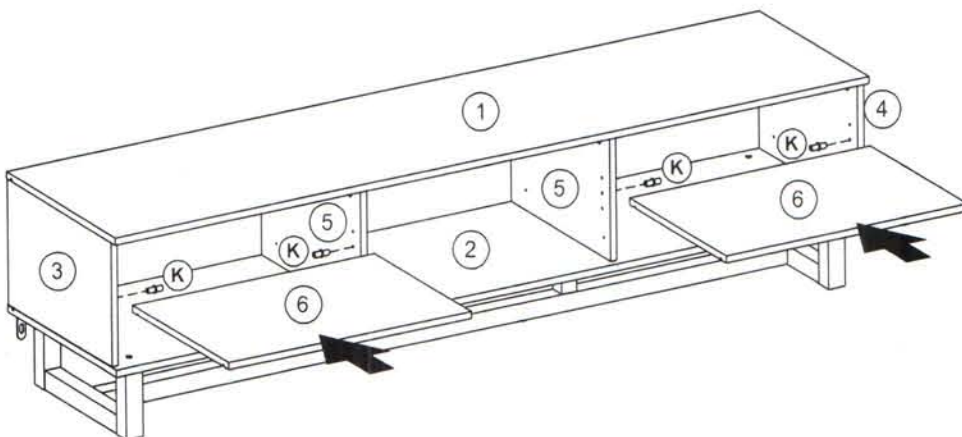

RZ1500WO

17

OPTION 2

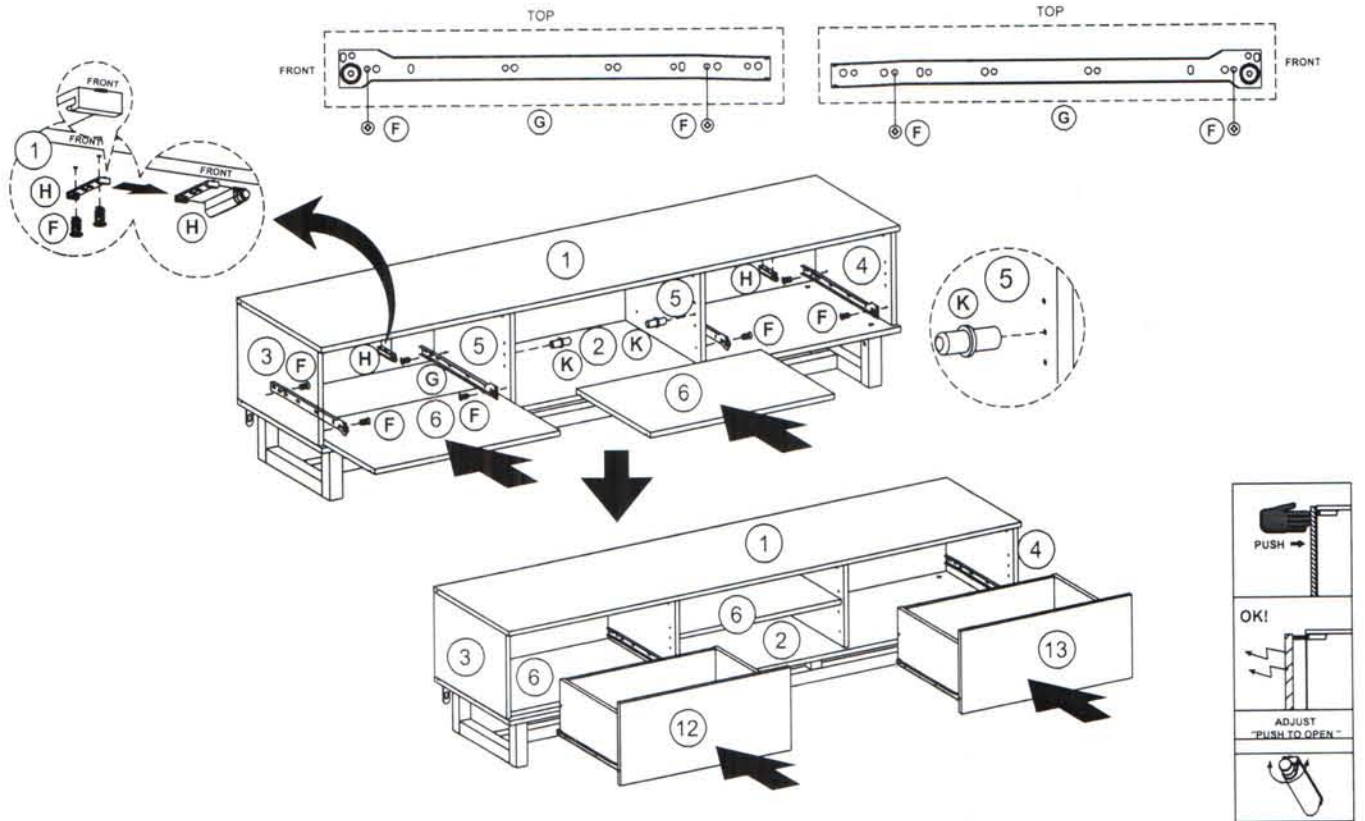
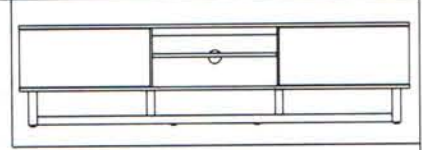

17

OPTION 3

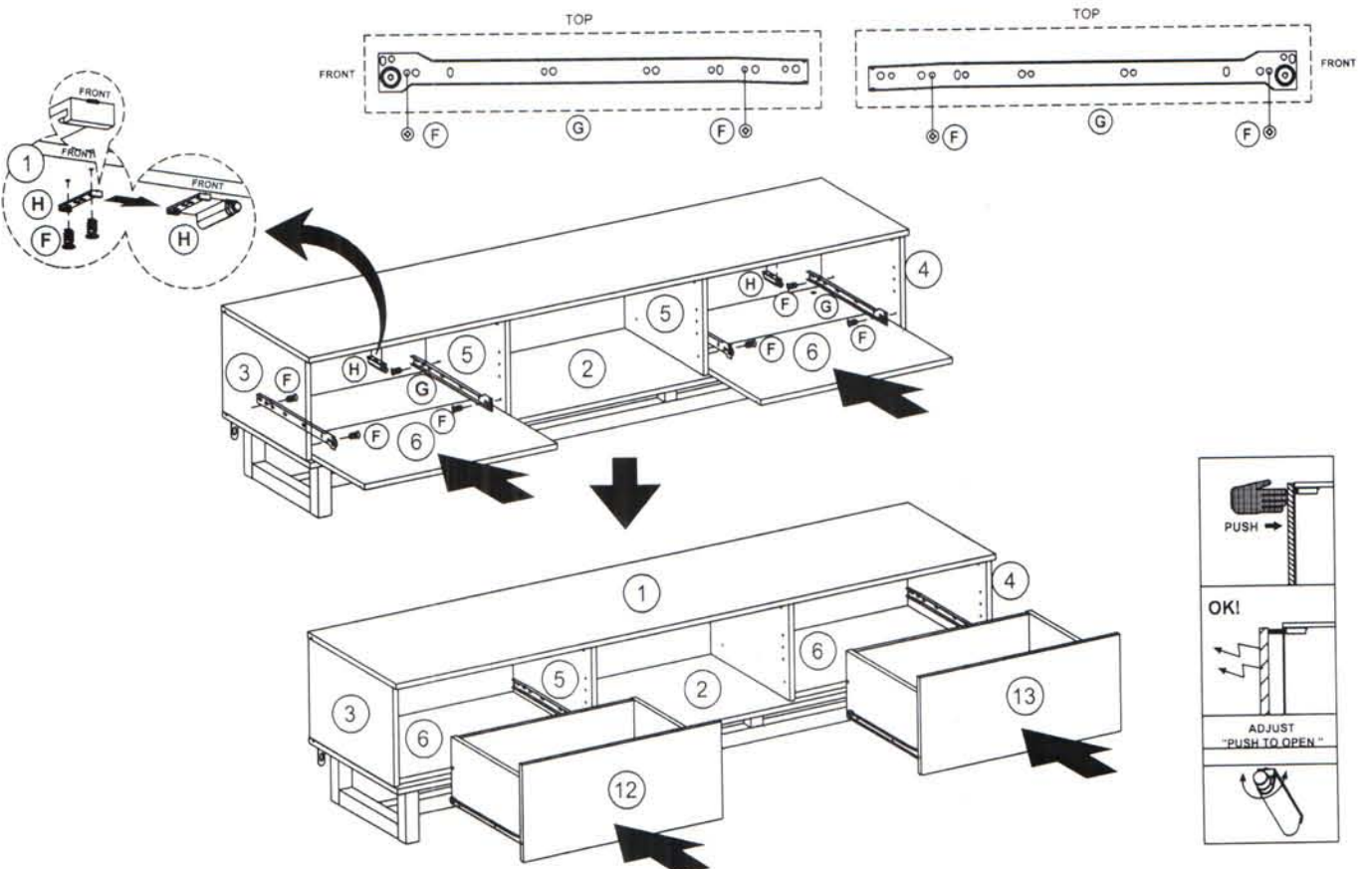
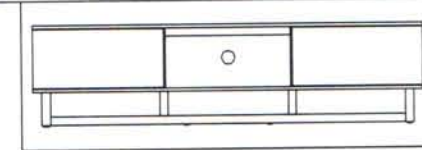

RZ1500WO

17

OPTION 4

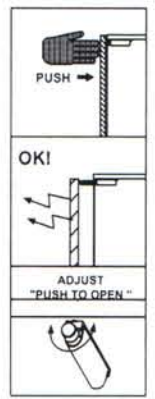
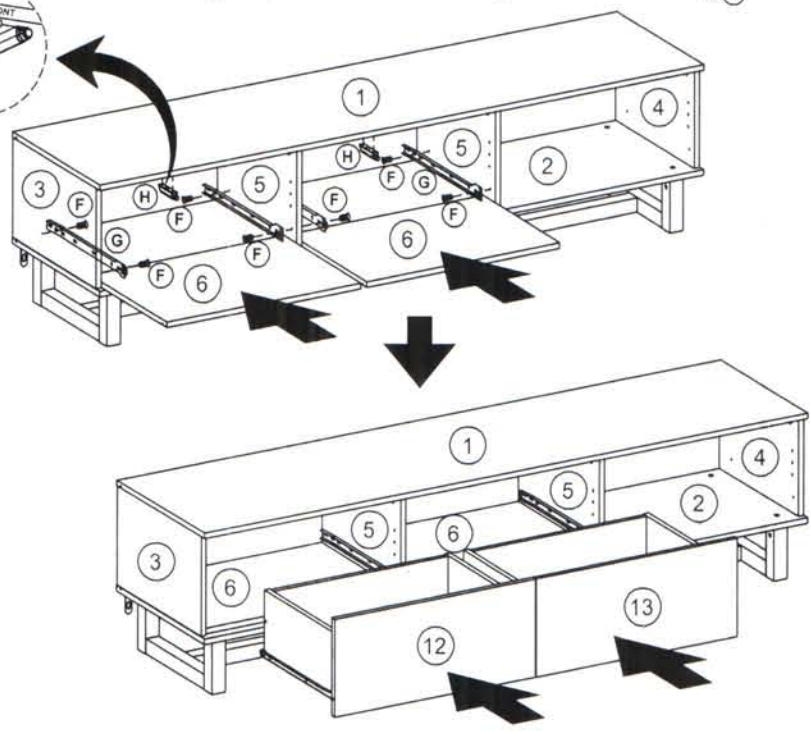
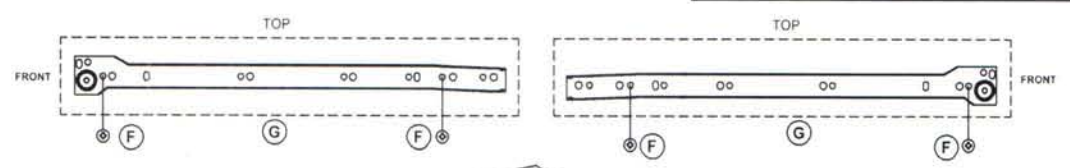
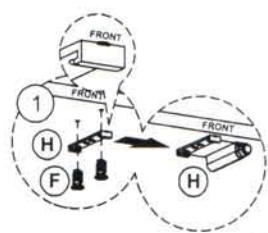
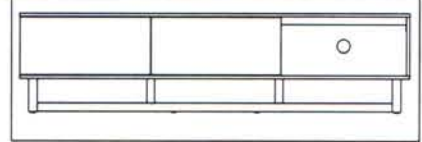

17

OPTION 5

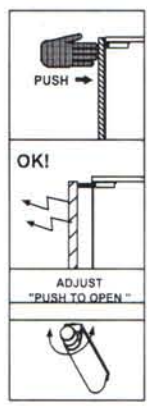
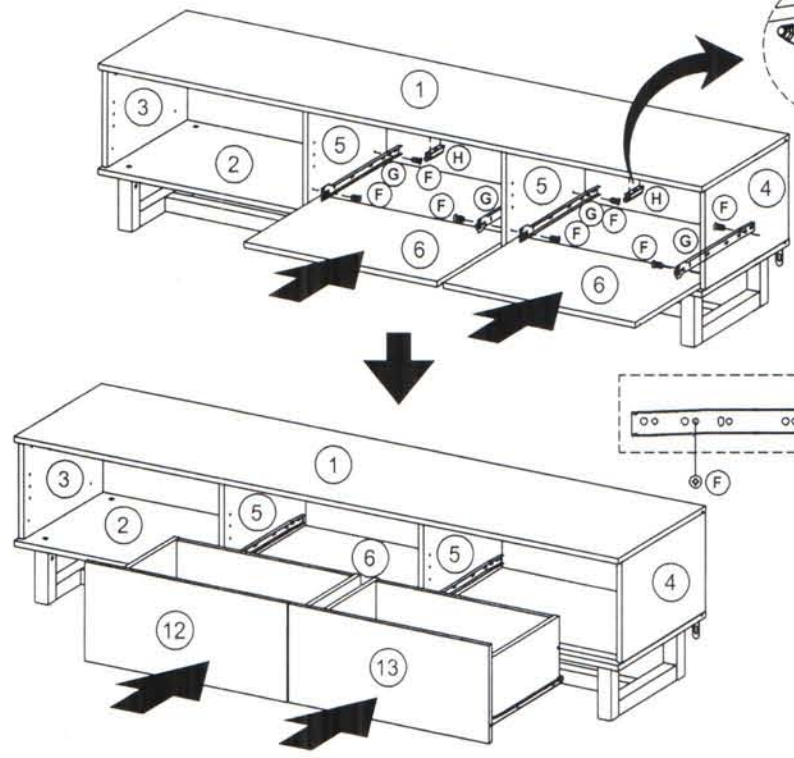
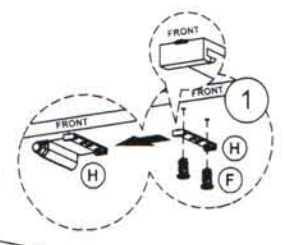
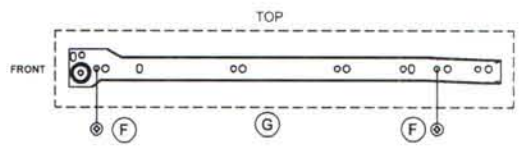
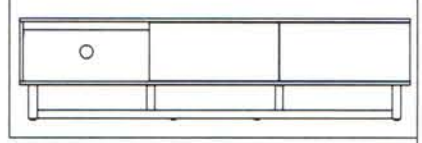

RZ1500WO

17

OPTION 6

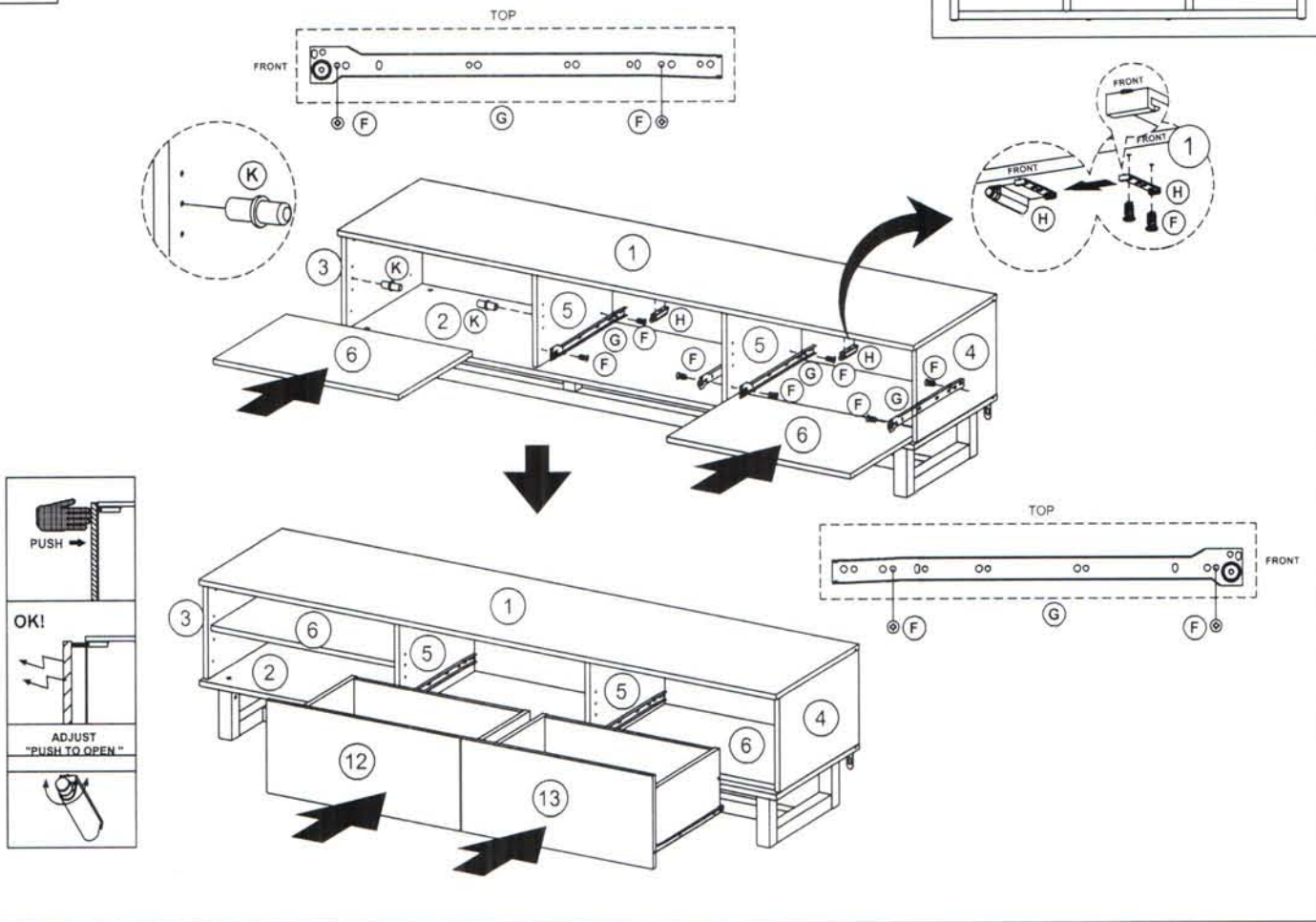
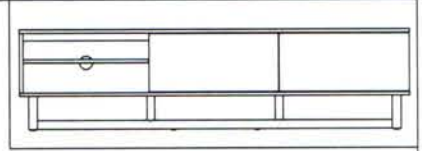

17

OPTION 7

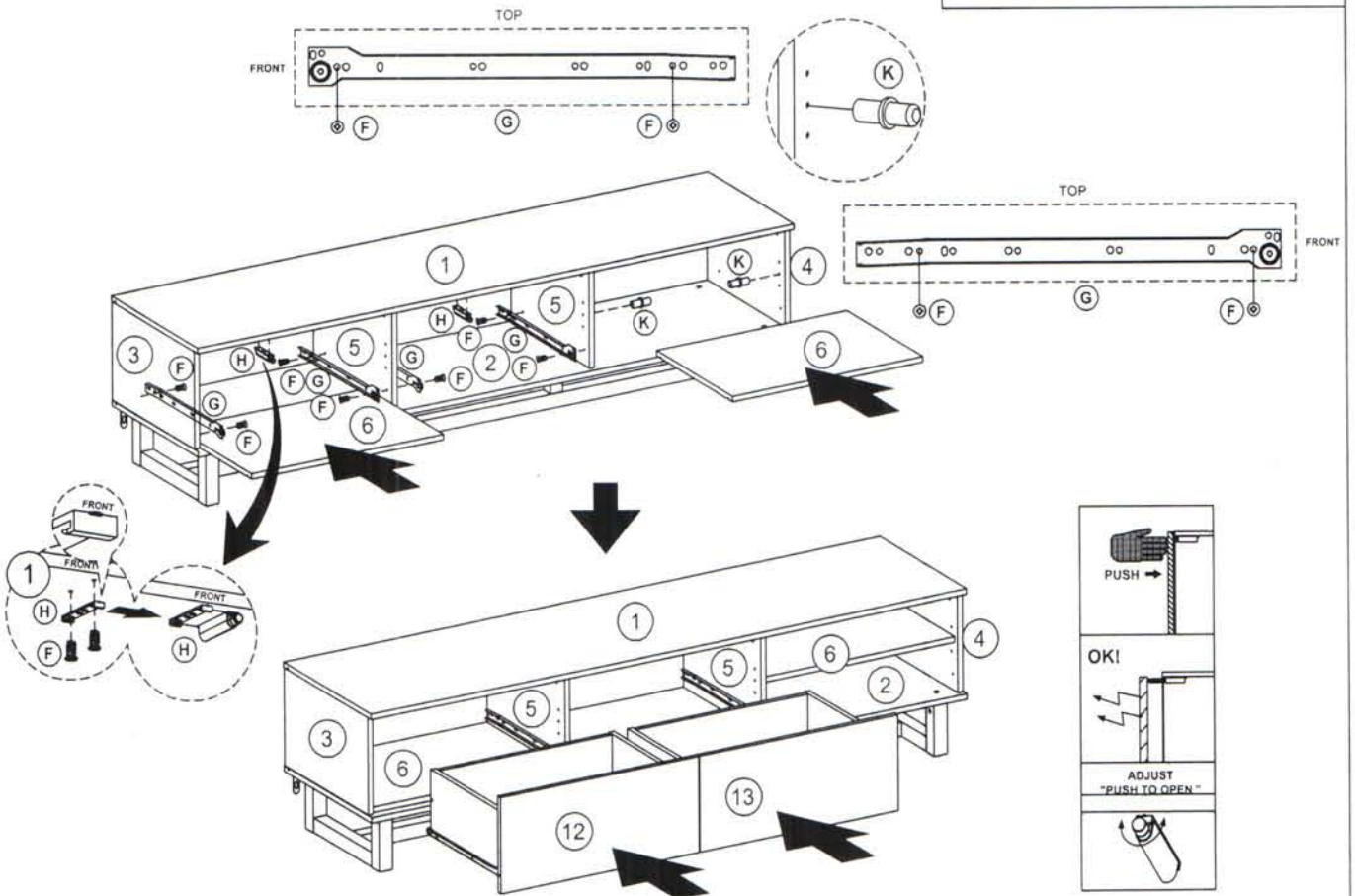
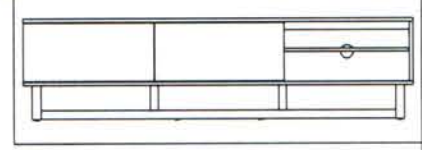

RZ1500WO

17

OPTION 8

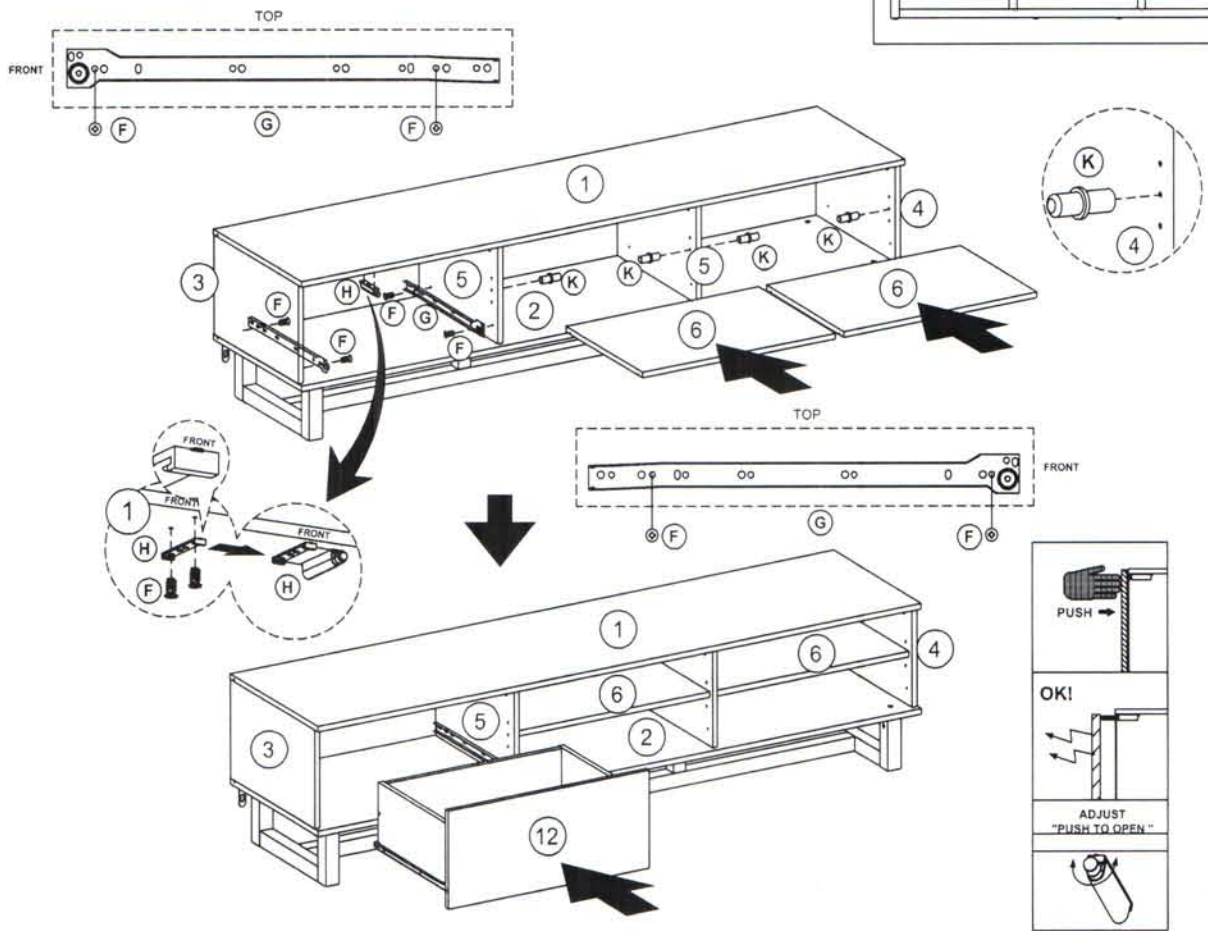

17

OPTION 9

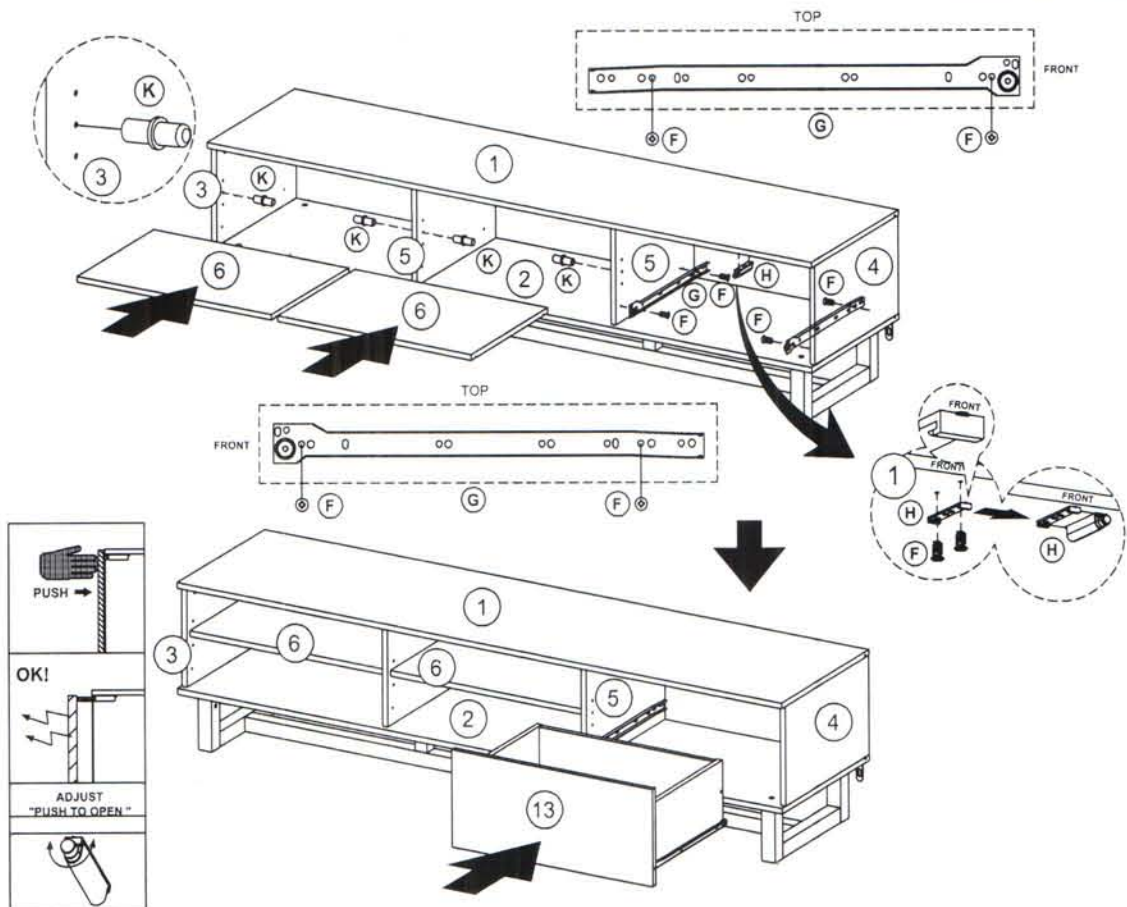

RZ1500WO

17

OPTION 10

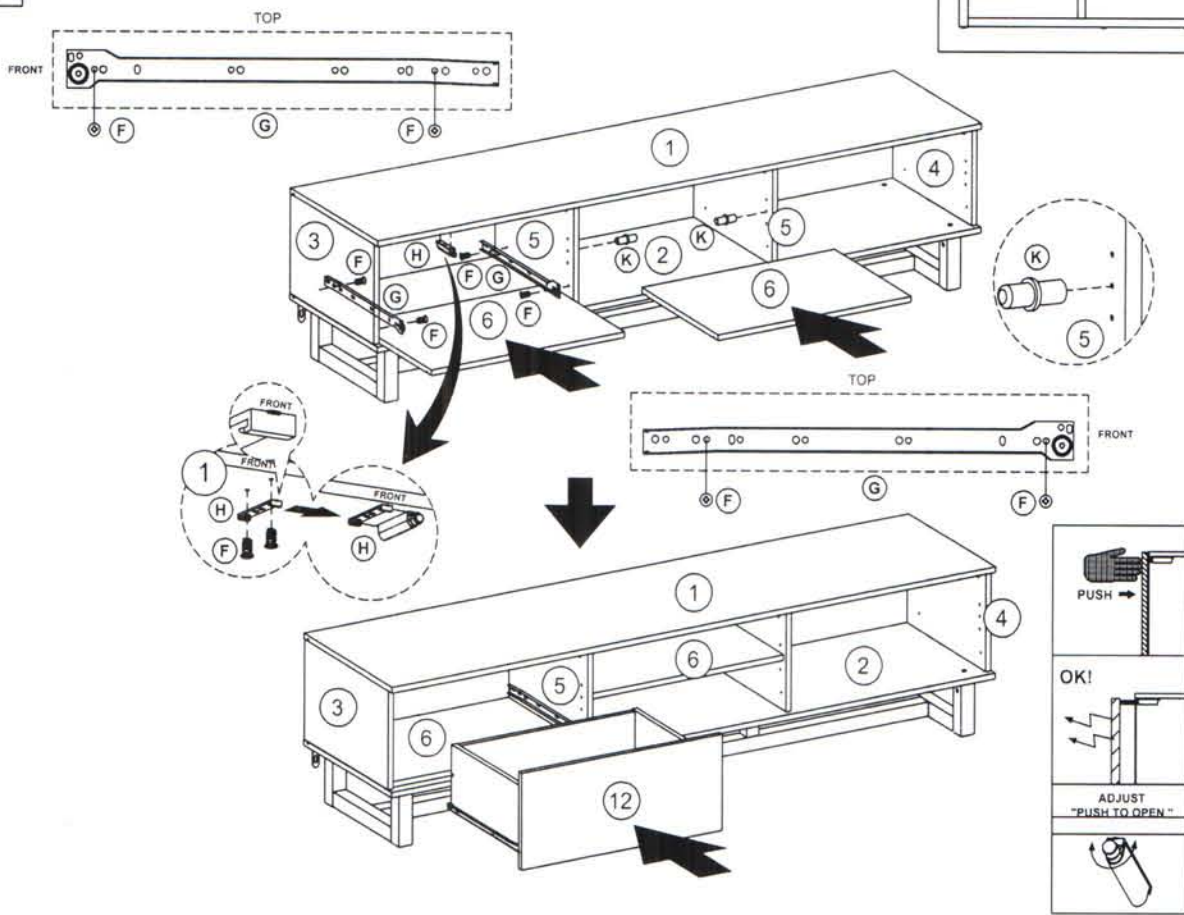

17

OPTION 11

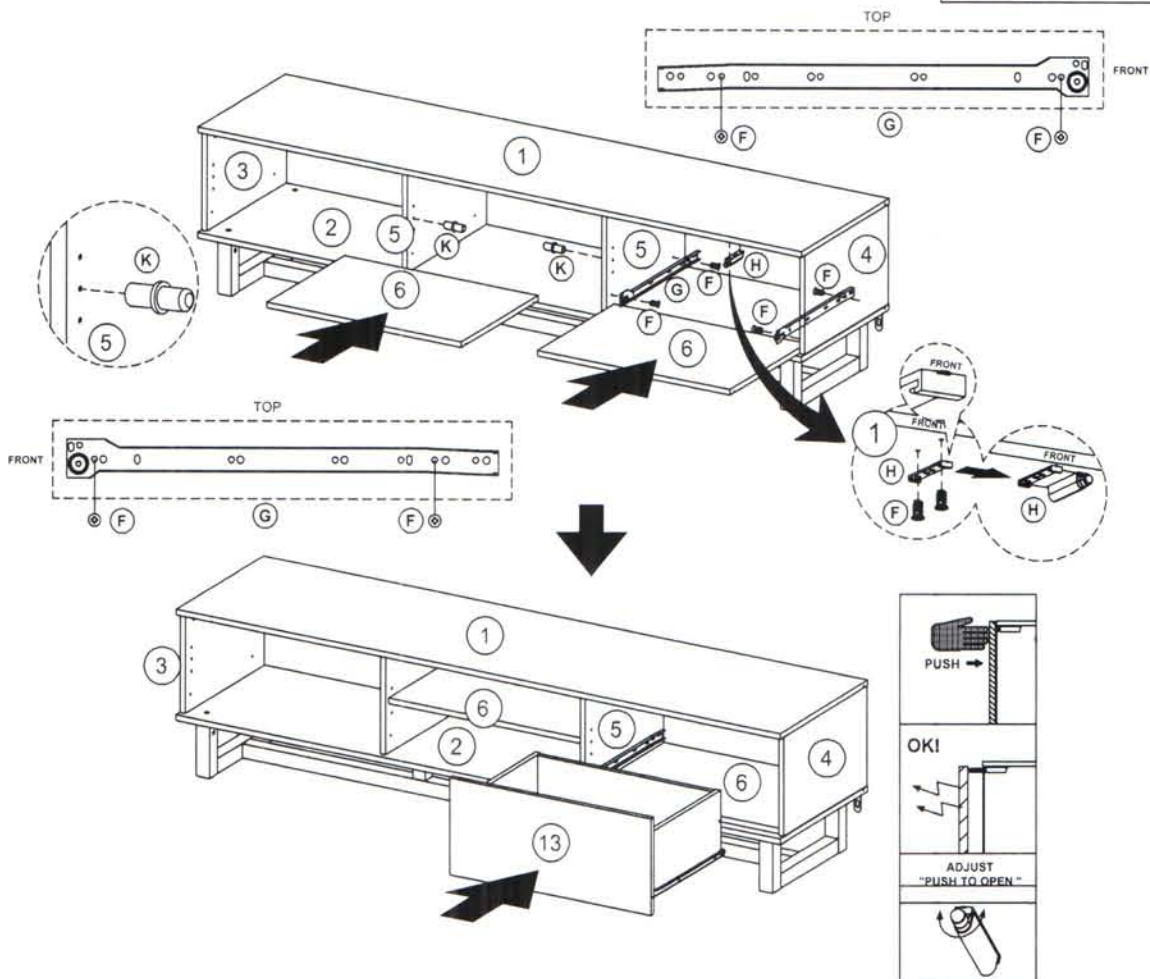

RZ1500WO

17

OPTION 12

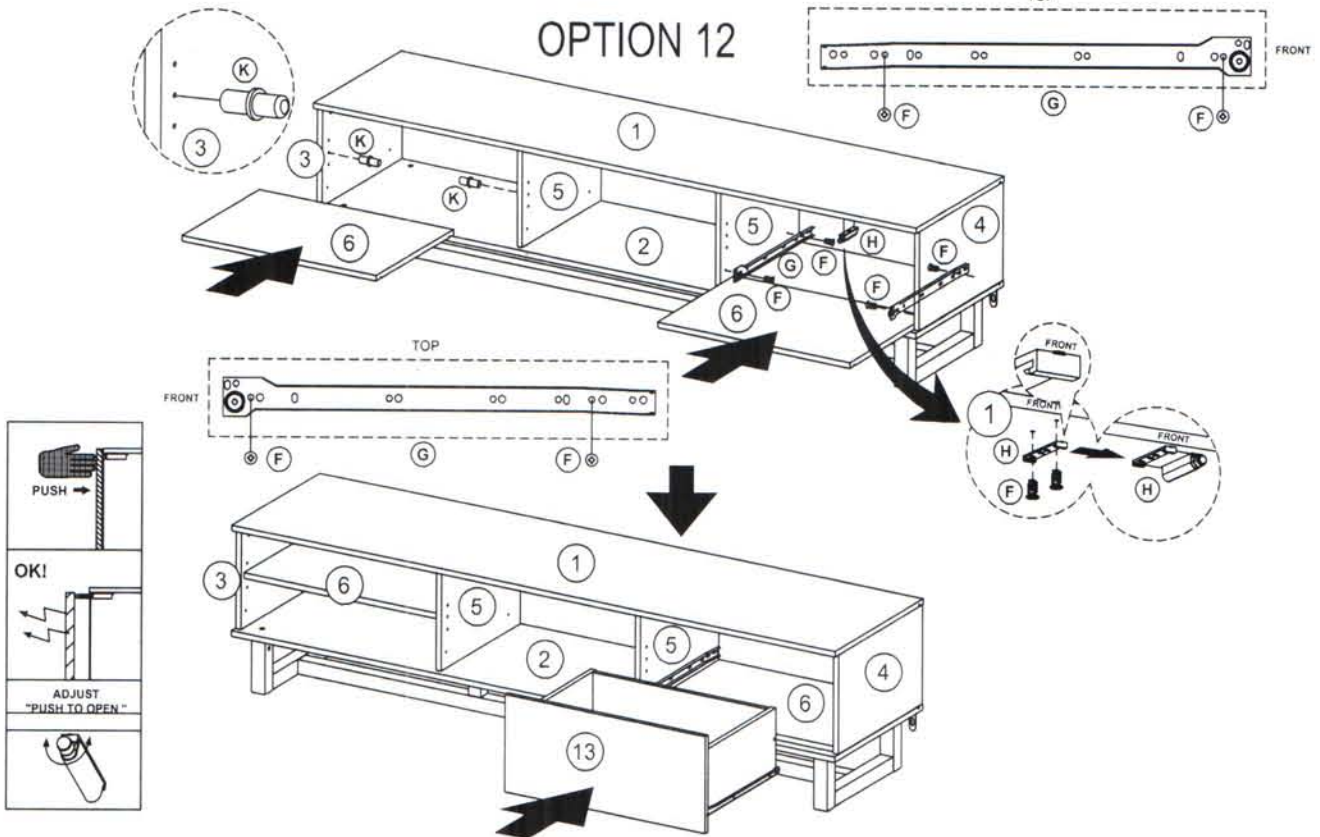
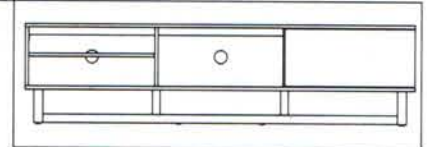

17

OPTION 13

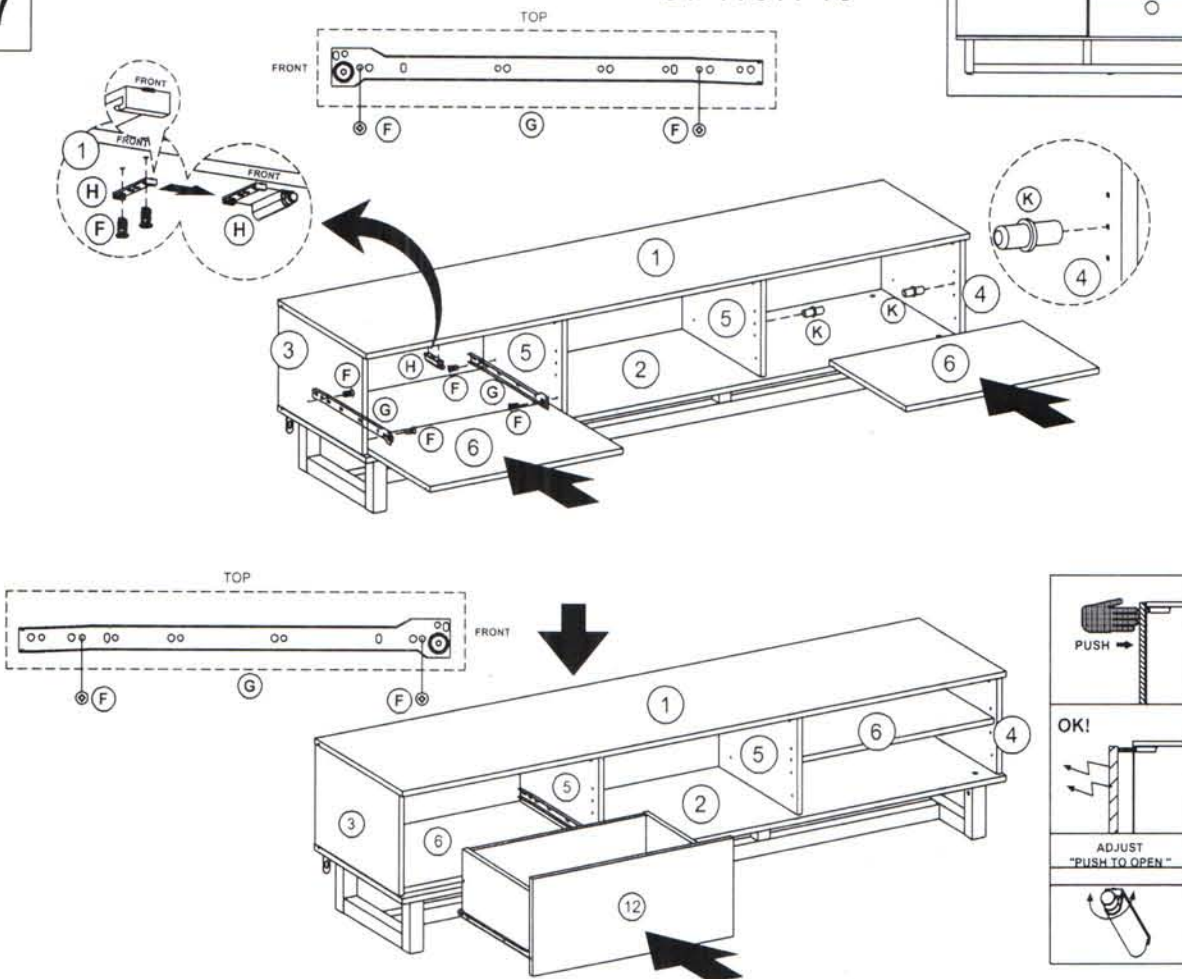
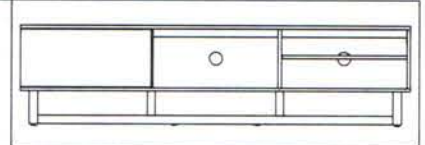

RZ1500WO

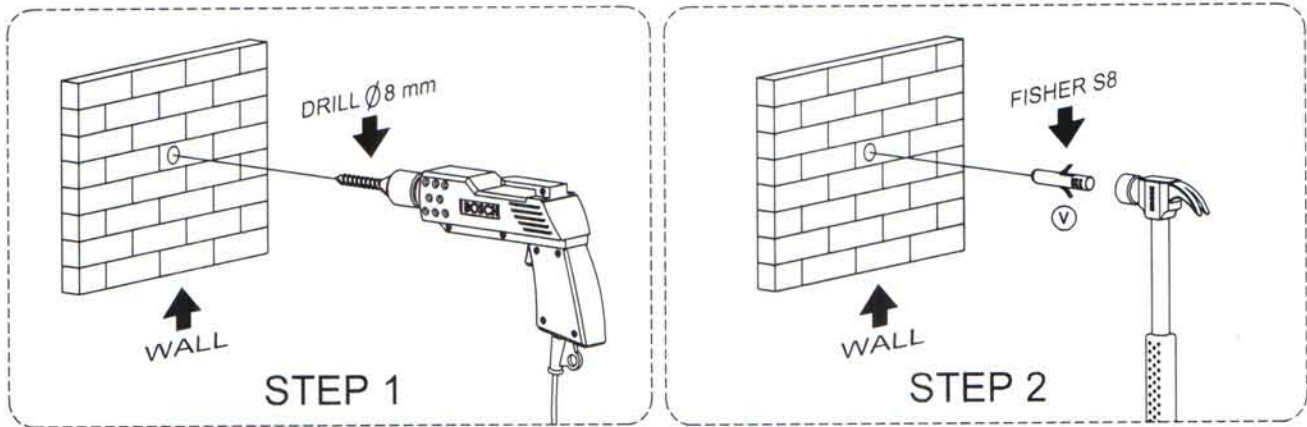

18

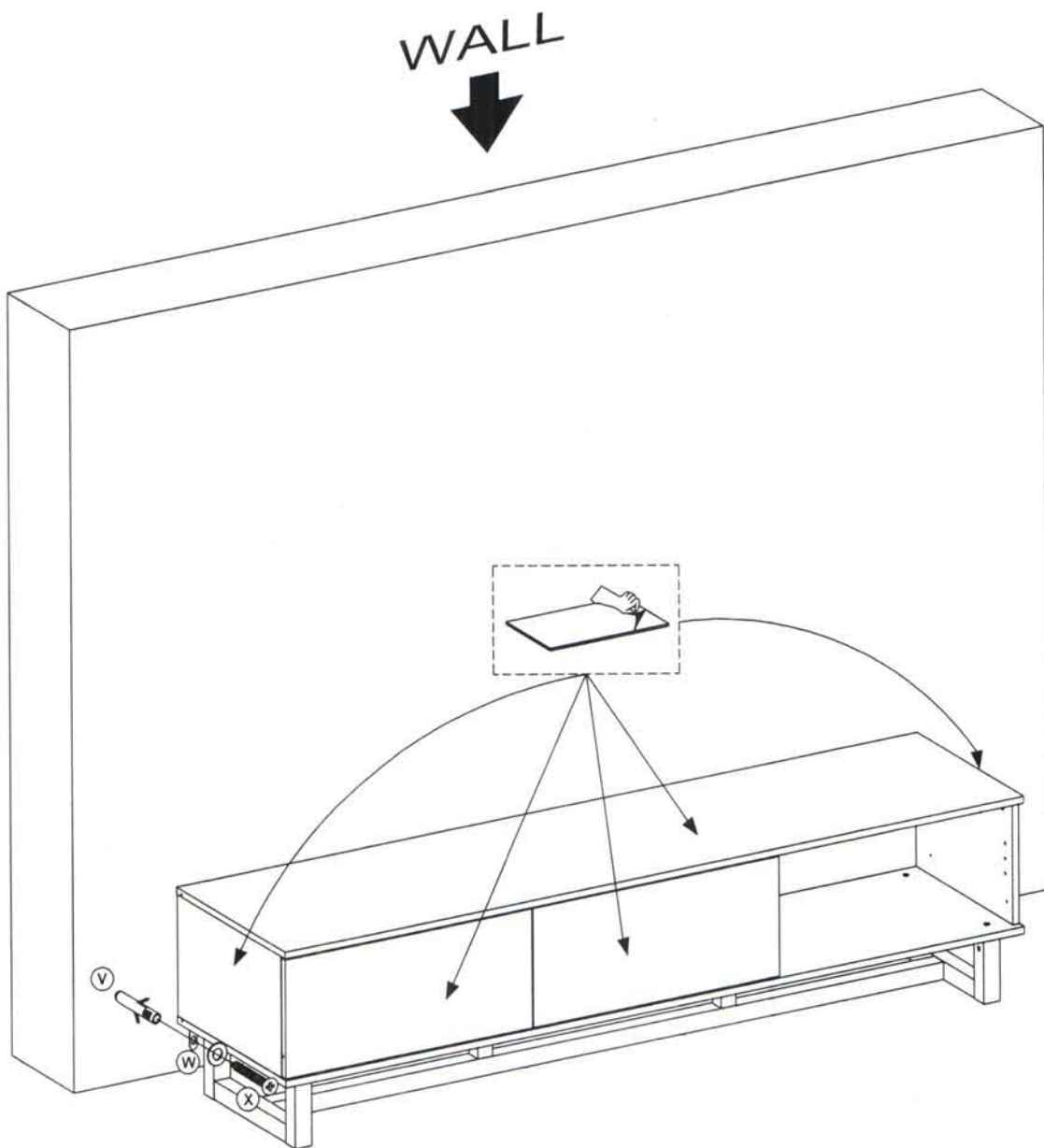

" We recommend using the safety bracket included or a Branded TV safety strap for your safety to prevent Cabinet & TV Tip over. "



" Remove the protective plastic film from the panels before your start assembling the cabinets."

| NO | ID PART | DRAWING PART | DESRPTION | UNIQUE CODE OF HARDWARE |
|----|---------|---|--------------------------------|-------------------------|
| 1 | A |  | CAMLOCK (15 X 12 MM) | RZ1500WOA |
| 2 | B |  | CAMBOLT (7,5 X 32 MM) | RZ1500WOB |
| 3 | C |  | CAM CAP (17 MM) | RZ1500WOC |
| 4 | D |  | PEN DOWEL (8 X 32 MM) | RZ1500WOD |
| 5 | E |  | FLAT HEAD SCREW (10 X 33,5 MM) | RZ1500WOE |
| 6 | F |  | FLAT HEAD SCREW (6 X 8 MM) | RZ1500WOF |
| 7 | G |  | RAIL SELF CLOSING (350 MM) | RZ1500WOG |
| 8 | H |  | PUSH TO OPEN | RZ1500WOH |
| 9 | I |  | CAM STICKER (20 MM) | RZ1500WOI |
| 10 | J |  | FLAT HEAD SCREW (6 X 13 MM) | RZ1500WOJ |
| 11 | K |  | SHELF PIN | RZ1500WOK |
| 12 | L |  | BACKPLY STOPPER | RZ1500WOL |
| 13 | M |  | FLAT HEAD SCREW (4 X 19 MM) | RZ1500WOM |
| 14 | N |  | PAN HEAD SCREW (3 X 12 MM) | RZ1500WON |
| 15 | O |  | FLAT HEAD SCREW (6 X 50 MM) | RZ1500WOO |
| 16 | P |  | BARREL NUT | RZ1500WOP |
| 17 | Q |  | SPRING RING | RZ1500WOQ |
| 18 | R |  | PAN HEAD SCREW (6 X 45 MM) | RZ1500WOR |
| 19 | S |  | ALLEN KEY | RZ1500WOS |
| 20 | T |  | PAN HEAD SCREW (4 X 10 MM) | RZ1500WOT |
| 21 | U |  | L-PLATE | RZ1500WOU |
| 22 | V |  | FISHER S8 | RZ1500WOV |
| 23 | W |  | WASHER PLATE | RZ1500WOW |
| 24 | X |  | FLAT HEAD SCREW (8 X 38 MM) | RZ1500WOX |

| NO | ID PART | DESRPTION | UNIQUE CODE OF HARDWARE |
|----|---------|----------------------------|-------------------------|
| 1 | 1 | TOP PANEL | RZ1500WO1 |
| 2 | 2 | BOTTOM PANEL | RZ1500WO2 |
| 3 | 3 | SIDE PANEL (LEFT) | RZ1500WO3 |
| 4 | 4 | SIDE PANEL (RIGHT) | RZ1500WO4 |
| 5 | 5 | DIVIDER PANEL | RZ1500WO5 |
| 6 | 6 | ADJUSTABLE SHELF | RZ1500WO6 |
| 7 | 7 | TOP PANEL PIPE SUPPORT | RZ1500WO7 |
| 8 | 8 | BACKPANEL | RZ1500WO8 |
| 9 | 9 | SIDE LEG | RZ1500WO9 |
| 10 | 10 | MIDDLE LEG | RZ1500WO10 |
| 11 | 11 | BOTTOM SUPPORT PANEL | RZ1500WO11 |
| 12 | 12 | FRONT DRAWER PANEL (LEFT) | RZ1500WO12 |
| 13 | 13 | FRONT DRAWER PANEL (RIGHT) | RZ1500WO13 |
| 14 | 14 | REAR DRAWER PANEL | RZ1500WO14 |
| 15 | 15 | LEFT DRAWER PANEL | RZ1500WO15 |
| 16 | 16 | RIGHT DRAWER PANEL | RZ1500WO16 |
| 17 | 17 | BOTTOM DRAWER PANEL | RZ1500WO17 |