

nexus 21

CONCEALMENT SYSTEMS

**Lift System Model AL-125
Installation Instructions**



Below is a parts list describing all of the items included with the Model AL-125 Lift System. Before beginning assembly and installation, please make sure that you have all items included on the list. If any parts are missing or damaged, please contact Nexus 21. Our contact information is shown at the top of this page.

Parts List



1. **Lift Column**
(22" x 4")



2. **Base Mount**
(7" x 3 1/2")



3. **Load Support Bracket**
(8" x 5 1/4")



4. **Control Box**
(8 1/4" x 3 3/4" x 1 1/2")



5. **Vertical Stabilizer (2)** – Accuride Model 3607-26
(26" x 2" x 3/4")

Cables

- **Motor Cable** – Black cable with white, six-pin connector (2 Meters). Use this cable to connect the Lift Column to the Control Box (using port 1 on the Control Box). Six feet long.
- **Power Cable** – Connects Control Box to power outlet (1 Meter). Three feet long.
- **RF Cable (only present if you ordered the RF version of the Lift System)** – Use to connect the RF Receiver to the Control Box. Ends have telephone-style (RJ45) connectors. One foot long.



TIP: You may want to install a power strip (not included) in the bottom of your cabinet to plug in the Lift System Control Box and any other components/appliances in the cabinet.

Hardware

- Two (2) -- #10 x 1 3/4" Flat Head Wood Screw (FHWS)
- Four (4) -- #8 x 3/4" Flat Head Wood Screw (FHWS)
- Eight (8) -- 6mm x 20mm Flat Head Machine Screw (FHMS)
- Sixteen (16) -- #10 x 3/4" Truss Head Wood Screw (THWS)
- Four (4) -- Lid Catch Brackets w/ (8) 10 x 3/4" (THWS)
- Two (2) – Tapered Pins
- One (1) -- Allen Wrench – 4mm

Cable Management

- Four (4) -- Wire Clips
- Four (4) -- Zip Ties

Types of Controls for Nexus 21 Lift Systems

All Nexus 21 Lift Systems come standard with a **wireless remote control** and receiver. We offer a choice of two different type of remotes: IR and RF (both of which are explained in detail below). Our standard control type is RF, so unless you specifically requested the IR version when you made your purchase, you probably received the RF controls with this Lift System. The method of installation for each type of remote control is slightly different, so you should now identify which type of remote you have by reading below, and then follow the instructions for that type of remote.

NOTE: If you will be using the Lift with a home control system (like the ones made by companies such as Crestron or Control 4) the most common form of control is to WIRE IT DIRECTLY to the relays of your home control system. This direct-wire method is called **Integration by Contact Closure**, and is accomplished by using the Backup Control Switch (Height Limit Switch) that was supplied with the Lift System to connect the Lift to the control unit from your home control system.

Before You Begin the Installation: Identify Your Control Type

IR (Infrared) – This control option allows you to utilize a 3rd party universal style remote control to raise and lower the TV Lift. Your universal remote will “learn” the IR codes from the provided IR Handset, which will enable you to control the lift. The universal remote will then communicate with the “eye” located on the IR Receiver via your 3rd party emitter (or flasher). Instructions for mounting the IR controls are on page 17. Instructions for setting the TV Lift’s travel limit are on Supplemental Page B.

NOTE: If you are NOT planning on using a 3rd party Universal Remote, switch to the RF setup. (There is no charge for swapping)

These are the parts included with IR controls:



Contact Closure Hardware



IR Receiver



IR Handset



Height Limit Insert

RF (Radio Frequency) - This system utilizes a wireless remote control handset that sends a radio signal to the RF Receiver. The radio signal can go through cabinet walls and does not require line-of-sight. Instructions for mounting the RF controls are on page 17. Instructions for setting the Lift System travel limit are on Supplemental Page B.

TIP: Planning to integrate the TV Lift with your UNIVERSAL REMOTE CONTROL? The RF version of the Nexus 21 controls won't do it. Switch to IR.

These are the parts included with RF controls:



Backup Switch



RF Receiver



RF Handset



Height Limit Insert

Integration by Contact Closure – To direct-wire the TV Lift controls to a home control system (Crestron, Control 4, AMX, etc.) you will use the Back-up Control Switch (Height Limit Switch). You won't use any Nexus 21 receiver or handset for this type of control because you will use the handset or control pad that comes with your home control system. **Instructions for setting up the System using Contact Closure are on “Supplemental Page C”.**

SAFETY INFORMATION

SEVERE PERSONAL INJURY AND PROPERTY DAMAGE CAN RESULT FROM IMPROPER INSTALLATION OR ASSEMBLY. READ THE FOLLOWING WARNINGS BEFORE BEGINNING.

WARNINGS:

1. Do not use this product for any application other than those specified by Nexus 21.
2. Do not exceed the weight capacity. This can result in serious personal injury or damage to the equipment. It is the installer's responsibility to ensure that the total combined weight of all attached components does not exceed that of the maximum figure stated.
3. Follow all technical specifications and instructions during the installation.
4. Only use attachments/accessories specified by the manufacturer.
5. Close supervision is necessary when this system is being used by, or near, children, or disabled persons.
6. It is the responsibility of the installer to warn all potential users of the dangers of interfering with the mechanism during operation.
7. Read all technical instructions fully before installation and use. It is the installer's responsibility to ensure that all documentation is passed on the users and read fully before operation.
8. Failure to provide adequate structural strengthening, prior to installation can result in serious personal injury or damage to the equipment. It is the installer's responsibility to ensure the structure to which the Lift System is affixed can support four times the weight of the system.
9. Risk of electric shock. Do not attempt to open the Control Box.
10. To reduce risk of fire or electric shock, do not expose parts to rain or other liquids.
11. Protect the power cord from being walked on or pinched.
12. Keep all documentation.
13. Heed all warnings.
14. Clean only with a dry cloth.
15. Refer all service questions to Nexus 21 if the system does not operate normally.

Nexus 21 disclaims any liability for modifications, improper installations, or installations over the specified weight range. Nexus 21 will not be liable for any damages arising out of the use of, or inability to use, Nexus 21 products. Nexus 21 bears no responsibility for incidental or consequential damages. This includes, but is not limited to, any labor charges for the servicing of Nexus 21 products performed by anyone other than Nexus 21. Nexus 21 intends to make this and all documentation as accurate as possible. However, Nexus 21 makes no claim that the information contained herein covers all details, conditions or variations, nor does it provide for every possible contingency in connection with the installation or use of this product. The information contained in this document is subject to change without prior notice or obligation of any kind. Nexus 21 makes no representation of warranty, expressed or implied, regarding the information contained herein. Nexus 21 assumes no responsibility for accuracy, completeness or sufficiency of the information contained in this document.

Assembly and Mounting Instructions – You Are Ready to Start

Please perform the following steps, in order:

Step 1: Inventory the Parts List. Carefully inspect all items, making sure you have everything shown in the Parts List.

Step 2: Seat the “pigtail” cable properly on the bottom of the Lift Column. Take the Lift Column (Part #1) and find the end with the short black cable (this cable is called the “pigtail”). This end will become the bottom of the Lift Column. Before you begin to assemble the lift system, you must position the pigtail properly. Look at the bottom edge of the Lift Column. You will see two square cut-out channels, notched into the steel, one on either side of the pigtail. Choose one of the cut-outs (it does not matter which one), and seat the pigtail into the cut-out, using the rubber gasket attached to the cable.



IMPORTANT NOTE: IF THE PIGTAIL CABLE IS NOT PROPERLY SEATED, IT MAY BE DAMAGED WHEN YOU ATTACH THE LOAD SUPPORT BRACKET (Part #3), CAUSING LOSS OF POWER TO THE LIFT COLUMN.

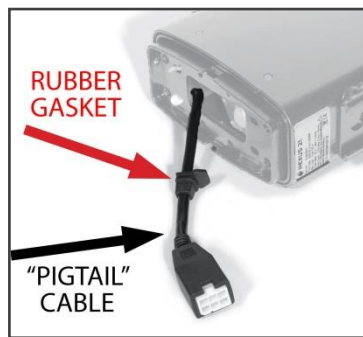

BEFORE (pigtail is loose)

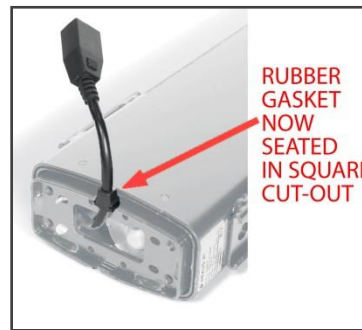

AFTER (pigtail is properly seated)



Step 3: Attach the Base Mount to the Bottom of the Lift Column. Find the Base Mount (Part #2). Using the small Allen wrench and four of the 6mm x 20mm Flat Head Machine Screws, attach the Base Mount to the bottom of the Lift Column (the end with the pigtail). The Base Mount has 8 holes – use the 4 innermost holes, which will align with the 4 threaded holes at the bottom of the Lift Column. **DO NOT OVER TIGHTEN!**

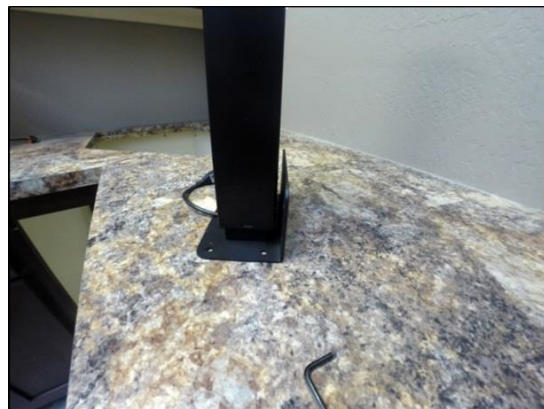

Step 4: Mounting the Load Support Bracket to the back of Box Assembly: Using (8) #10 x 3/4" THWS attach the Load Support Bracket to the back of your Box Assembly. Use two screws towards the top, middle and bottom of bracket. Now use two screws on the bottom side of the box, to fasten the L-shaped bracket to the bottom of the box.



NOTE: You may need to use a block between the bottom of the Box Assembly and the Load Support Bracket depending on the height of your Box Assembly.

IMPORTANT NOTE: When installing your cabinet, make sure it rests 1/8"-1/4" below the lip edge of the countertop where the lid will sit. This will make sure our collision detection software is not engaged from the lift running into your lid suddenly when operated.

YOU CANNOT ATTACH THE LID TO THE CABINET; YOU MUST USE OUR TAPERED PINS.

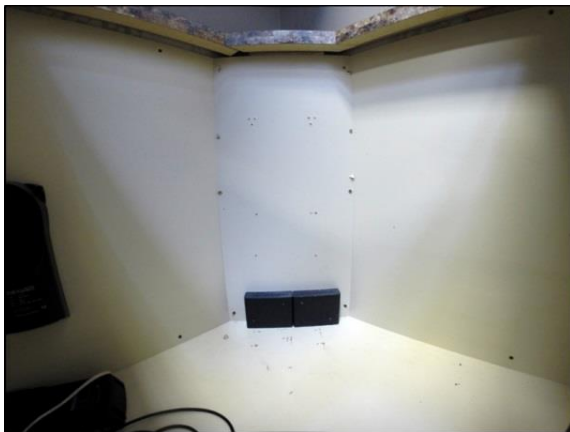

Step 5a: Mounting Lift Column inside of Cabinet: Position lift column inside cabinet against the back wall and determine if you need to block the lift forward. The lift column when extended should clear the opening of the cabinet by 1/2".

Step 5b: Determine if a platform or block is needed to raise the lift system up off of the base of the cabinet. Measure the height of the Box Assembly by measuring from the bottom of the Lift Column to the top of your Box Assembly (including the countertop thickness). Subtract this dimension from the total height of your cabinet, measured from the bottom surface of your enclosure to the countertop surface. If the total height of the Box Assembly is shorter than the total height of your cabinet you must build a simple platform (typically made of wood) to raise the assembly so the top of your Box Assembly is within 1/2" of the countertop surface. Use the formula on the following page to determine the proper height of the platform



Platform Height = (Enclosure Interior Height + Countertop Thickness) – Lift Box Assembly Height

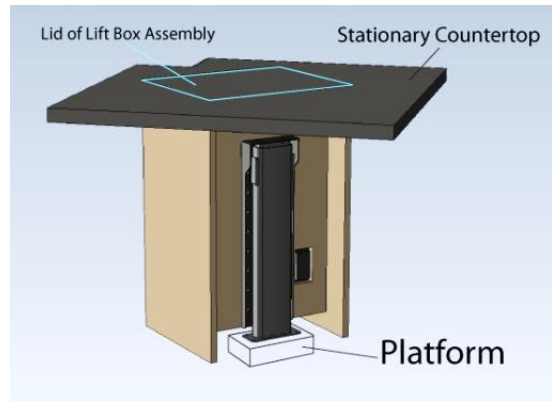
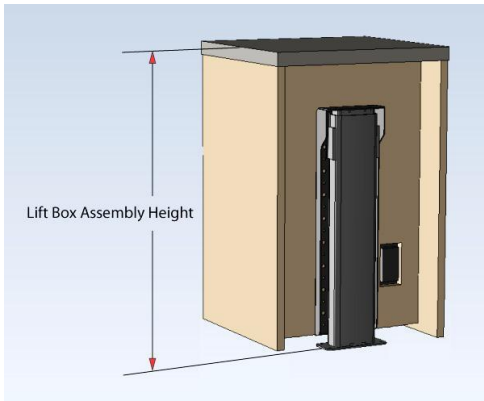

Step 6a: Fasten the Base Mount to the inside of the cabinet. Using (8) #10 x 3/4" THWS mount the Base Mount to either your platform or the base of the cabinet.

Step 6b (Optional): Fasten the (4) Steel Corner Brackets to the platform or block the lift is sitting on to the base of the cabinet. This will provide additional stability to prevent lateral movement from the platform.



Step 7: Connect the controls. Refer to the wiring diagram on the following page to connect the **IR Controls** and **Control Box**. The diagram for the **RF controls** can be found on page 9.

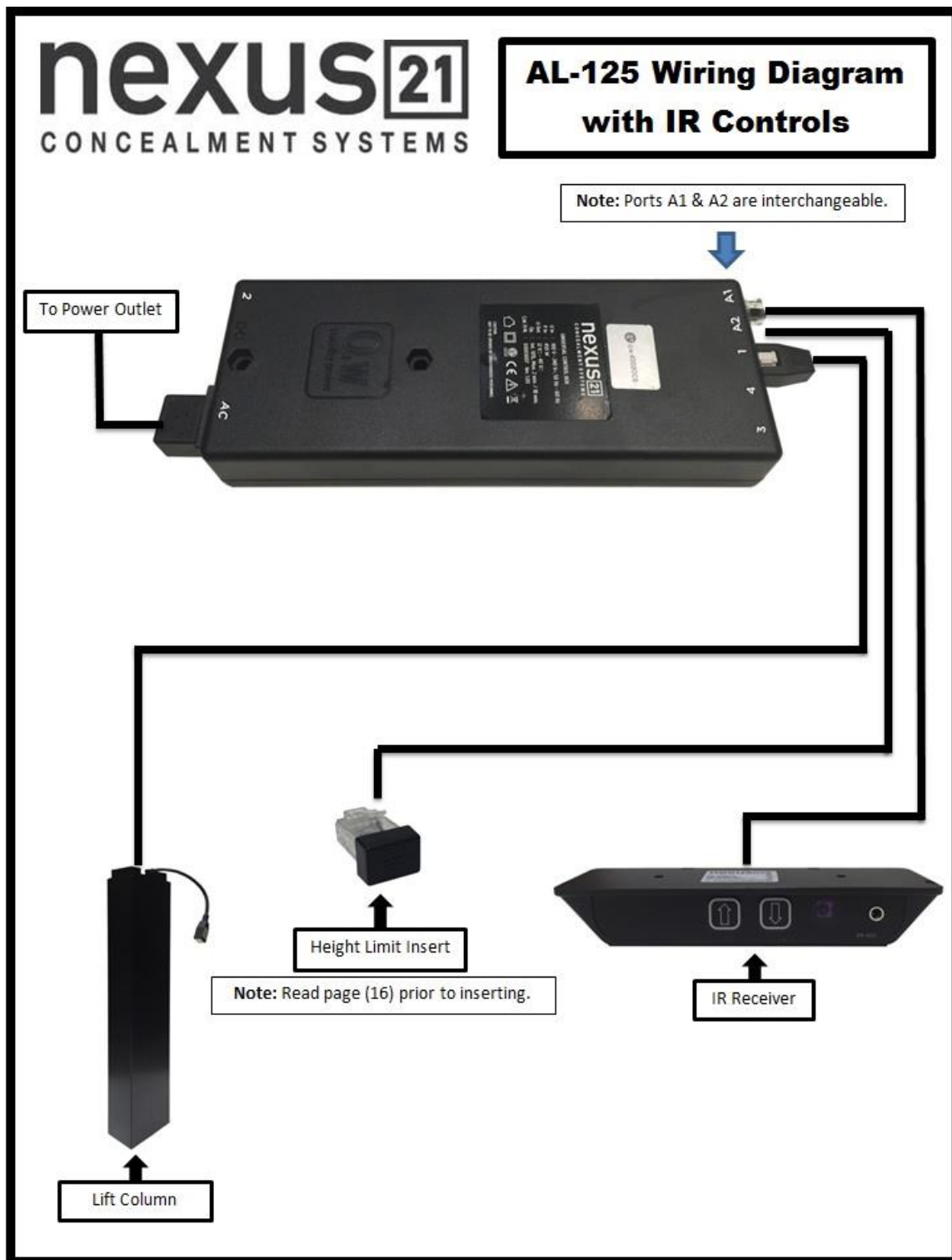

Once you have connected the controls, test the Lift Column as follows:

First, you need to “initialize” the Lift System. If you have already raised the Lift Column, lower it again, since this step must be performed in the “down” position. Find the Backup Control Switch, which has two triangle-shaped buttons - an UP (with raised dot) and a DOWN. Press the DOWN button and HOLD IT DOWN for approximately 5 seconds. You should see a slight movement in the Lift Column. If you do not see the movement, release the Down button, and repeat the process - press and hold the Down button again for 5 seconds. Once you have seen the slight movement, the Lift System is now functional. Test it by pressing the Up button (no need to hold the Up button) and the lift will go up. You may let it go to the top, or stop it at any time by pressing the Down button.

IF YOU HAVE RF CONTROLS, USE THIS DIAGRAM (for IR Controls, see the previous page)

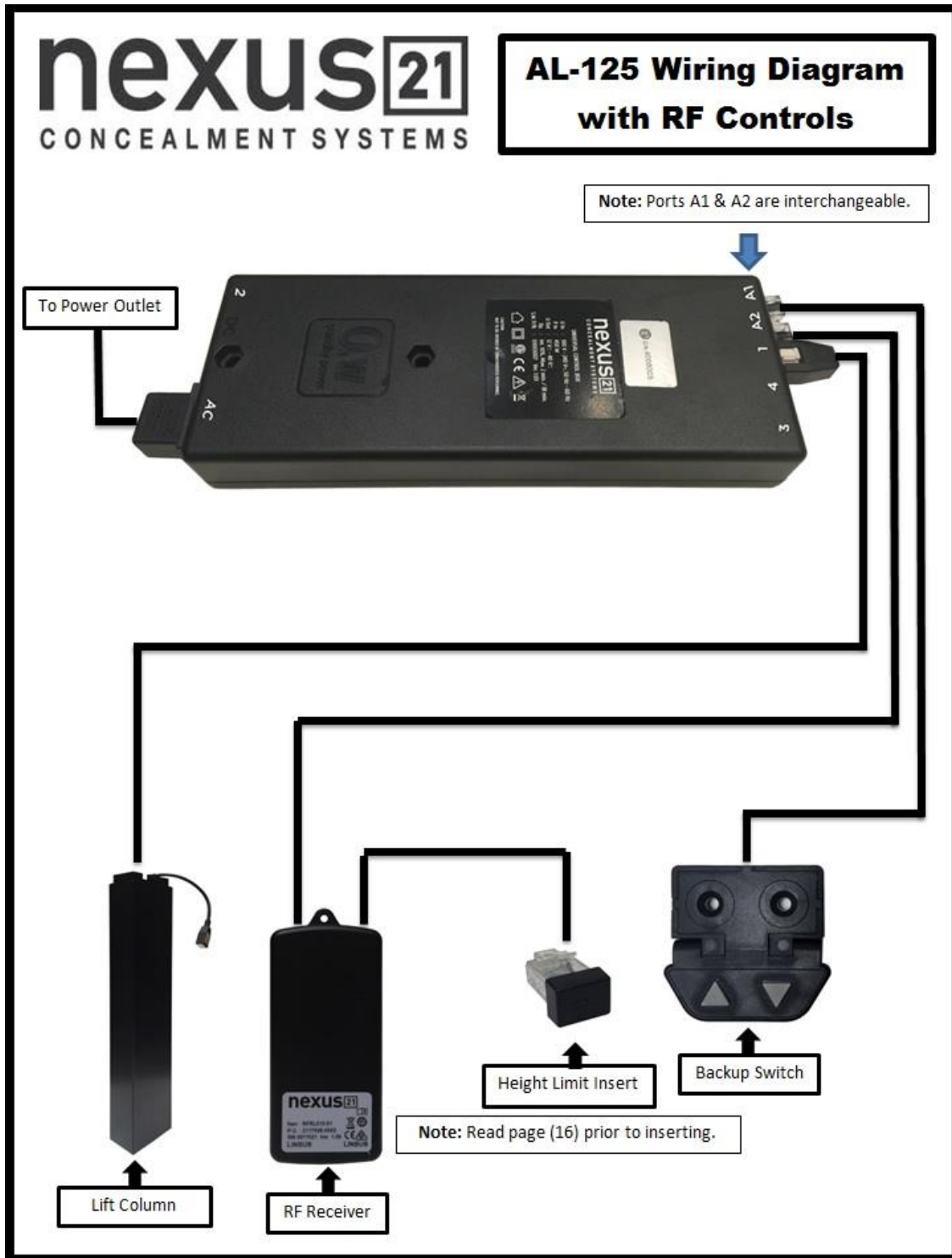

Once you have connected the controls, test the Lift Column as follows:

First, you need to "initialize" the Lift System. If you have already raised the Lift Column, lower it again, since this step must be performed in the "down" position. Find the Height Limit Switch, which has two triangle-shaped buttons - an UP (with raised dot) and a DOWN. Press the DOWN button and HOLD IT DOWN for approximately 5 seconds. You should see a slight movement in the Lift Column. If you do not see the movement, release the Down button, and repeat the process - press and hold the Down button again for 5 seconds. Once you have seen the slight movement, the Lift System is now functional. Test it by pressing the Up button (no need to hold the Up button) and the lift will go up. You may let it go to the top, or stop it at any time by pressing the Down button.

Step 8: Reinitialize/Reset the lift system. With the lift in the fully retracted position, hold the down button on the manual back up switch (the grey pad with two triangle buttons) for 3-5 seconds. You should see the lift column make a slight up and down jog motion; this will let you know the lift system has successfully been reset. If you do not see the jog motion within the first 3-5 seconds, then release the down button and try again. Once you have successfully reset the lift system then proceed to the next step.



Step 9: Extend the lift column while it is positioned inside the cabinet. Make sure the lift column has about $\frac{1}{2}$ " clearance on the back side of the column, to ensure lift column does not run into counter top while extending. This is the time to make any necessary adjustments to the position of the lift column.

IMPORTANT NOTE: Make sure when the lift is fully retracted, the cabinet rests $\frac{1}{8}$ " – $\frac{1}{4}$ " below your lip edge. This will make sure our collision detection software is not engaged from the lift running into your lid suddenly when operated. **YOU CANNOT ATTACH THE LID TO THE CABINET; YOU MUST USE OUR TAPERED PINS.**

NOTE: Do not bump into column while it is in the "Extended Position," as the column may tip over.

Step 10a: Using (6) #8 x $\frac{3}{8}$ " FHWS attach both drawer glides to the back of your Lift Box Assembly to provide additional stability. Depending on the shape of your lift box assembly the drawer glides may be mounted on the sides or the back of your Lift Box Assembly.





Step 10b: Create two Vertical Stabilizer support beams on the inside of the cabinet to attach the bottom half of the Vertical Stabilizers. Using 2x4 wood beams, create a structure to fasten each Vertical Stabilizer to.



Step 11: Attach your Lift Box Assembly to the top of the lift Column. Using (4) 6mm x 20mm FHMS attached your Lift Box Assembly to the top of the Load Support Bracket while the lift fully extended.

NOTE: Depending on the size and design of your Box Assembly, you may need to create a notch into the "Lip" of opening of the counter top, allowing the Vertical Stabilizers to function properly.





Step 12: Using (6) #8 x $\frac{3}{4}$ " FHWS Fasten the bottom of the Vertical Stabilizers to the drawer glide support beams you created on step 6b.

NOTE: Run the lift up and down a few times to test Vertical Stabilizers fitment. Make appropriate adjustments at this stage.

Step 13: Attaching Tapered Pins to the underside of your Lid: Use a $\frac{7}{32}$ " bit to drill two $\frac{1}{2}$ " holes on the underside of your lid. Use a Phillips Screwdriver to screw the tapered pins into the underside of your lid. Once you have the tapered pins installed on the lid, mark the same position on the top of your Lift Box Assembly, where the Tapered Pins will go through and drill two holes through the top of your Lift Box Assembly to allow the Tapered Pins to slide into.





NOTE: Step 13 is designed to give the Lid a “Break-Away” feature, to prevent any finger injury in case someone has their hand in the way while the lift is traveling down.

IMPORTANT NOTE: Make sure when the lid rests 1/8”-1/4” above your cabinet when the lift is FULLY retracted. This will make sure our collision detection software is not engaged from the lift running into your lid suddenly when operated. **YOU CANNOT ATTACH THE LID TO THE CABINET; YOU MUST USE OUR TAPERED PINS.**

Step 14a: Mounting the Controls: Using (4) #10 x 3/4” FHWS mount the Control Box in an accessible location near the lift column. Make sure this location is accessible when the lift is both extended and retracted.



Step 14b: Using (2) #6 x 3/4” RHWS located in the RF Kit, mount the RF Receiver next to the Control Box.

Step 14c: Using (2) #8 x 3/4” FHWS, mount the manual back-up switch under the counter top lip or a nearby location.



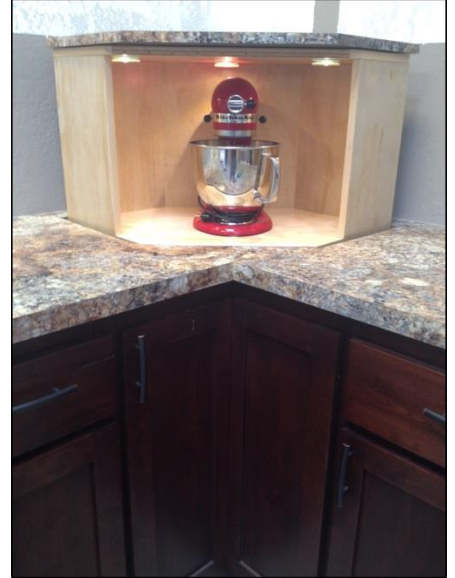
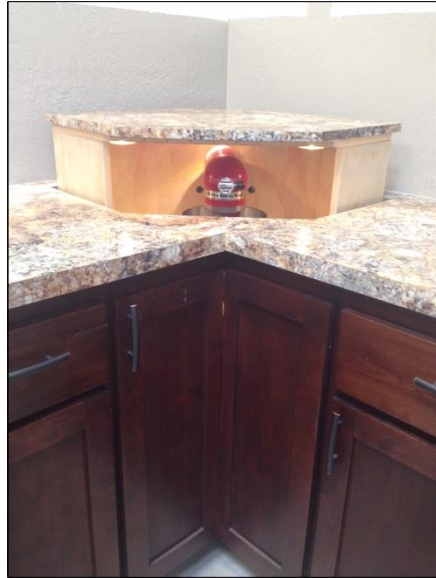
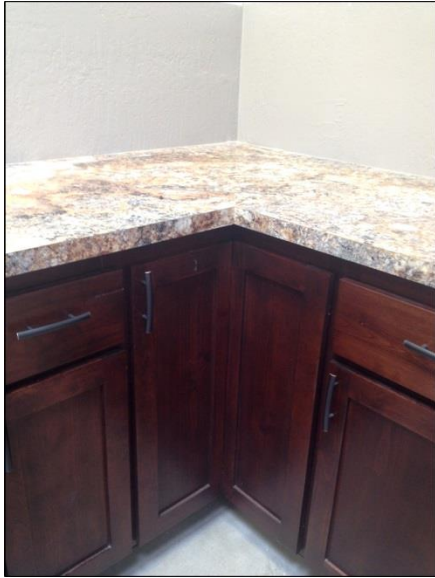

Congratulations your AL-125 Hidden Storage Lift System is now installed!

MODEL AL-125 CONCEALED STORAGE LIFT STANDARD CONFIGURATION

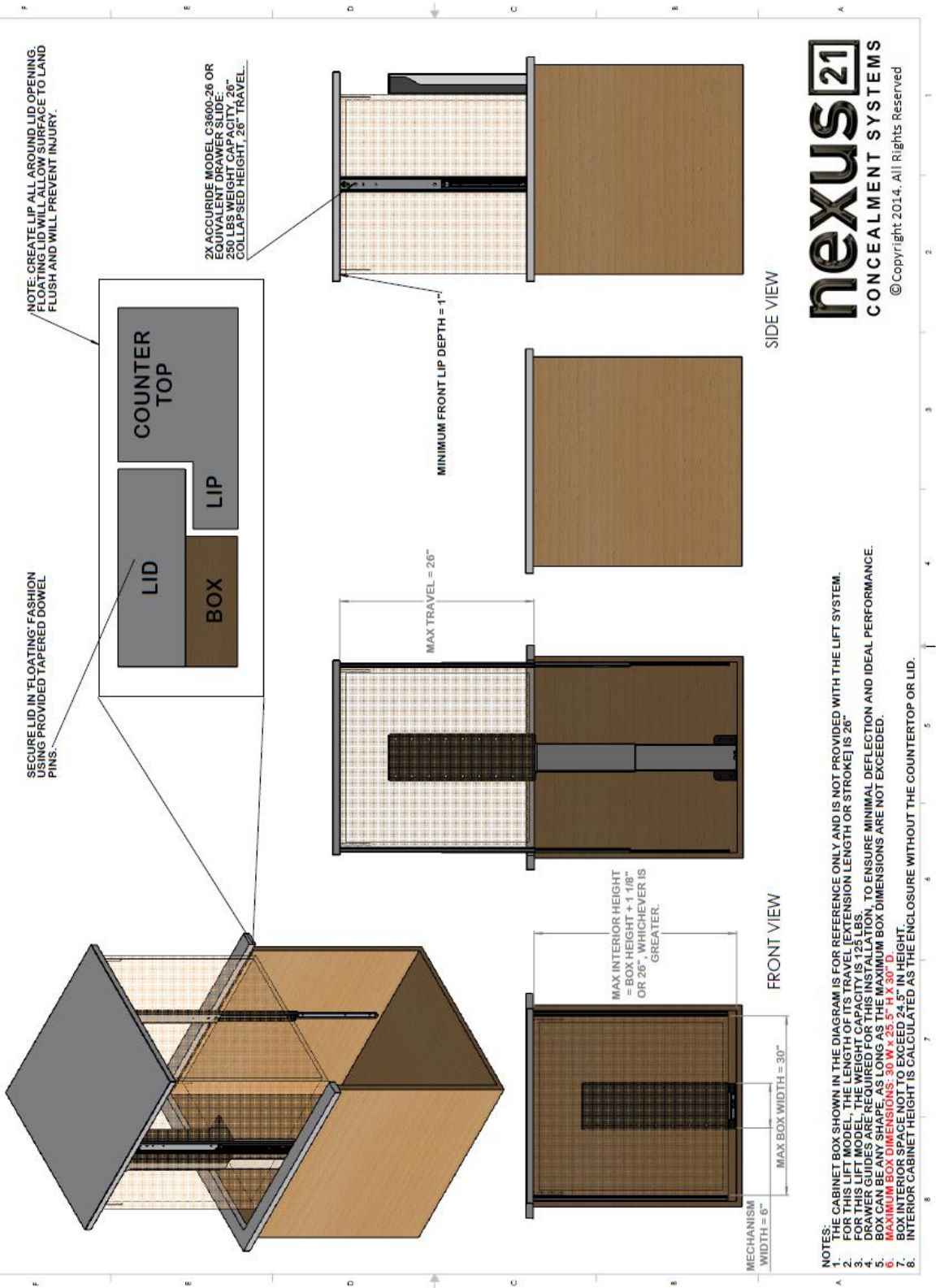

nexus21
CONCEALMENT SYSTEMS
 © Copyright 2014. All Rights Reserved

- NOTES:**
1. THE CABINET BOX SHOWN IN THE DIAGRAM IS FOR REFERENCE ONLY AND IS NOT PROVIDED WITH THE LIFT SYSTEM.
 2. FOR THIS LIFT MODEL, THE LENGTH OF ITS TRAVEL [EXTENSION LENGTH OR STROKE] IS 26".
 3. FOR THIS LIFT MODEL, THE WEIGHT CAPACITY IS 125 LBS.
 4. GRAB BAR GUIDES ARE REQUIRED FOR THIS INSTALLATION, TO ENSURE MINIMAL DEFLECTION AND IDEAL PERFORMANCE.
 5. MAXIMUM BOX DIMENSIONS: 30" W x 25.5" H x 30" D.
 6. MAXIMUM BOX DIMENSIONS: 30" W x 25.5" H x 30" D.
 7. BOX INTERIOR SPACE NOT TO EXCEED 24.5" IN HEIGHT.
 8. INTERIOR CABINET HEIGHT IS CALCULATED AS THE ENCLOSURE WITHOUT THE COUNTERTOP OR LID.

Supplemental Page B: Setting a Height Limit

Please follow this procedure if you would like to limit the distance that your TV Lift extends.

To set your Travel Limit with IR Controls:

If you want the lift system to always go to its full extension, do NOT use the Height Limit Insert. Simply leave it unplugged and the system will always travel to the full extension. To limit the travel, follow the procedure below:



1. Using the IR Receiver, run the lift to the ideal height limit position and stop it.

2. With the lift system stopped, plug the Height Limit Insert into the available RJ45 port on the Control Box. This will set the height limit at this position for both the IR Remote (or 3rd party universal remote) and the IR Receiver.

3. If the height limit is set at the incorrect position, remove the Height Limit insert and repeat the procedure.

To set your Travel Limit with RF Controls:

If you want the lift system to always go to its full extension, do NOT use the Height Limit Insert. Simply leave it unplugged and the system will always travel to the full extension. To limit the travel, follow the procedure below:

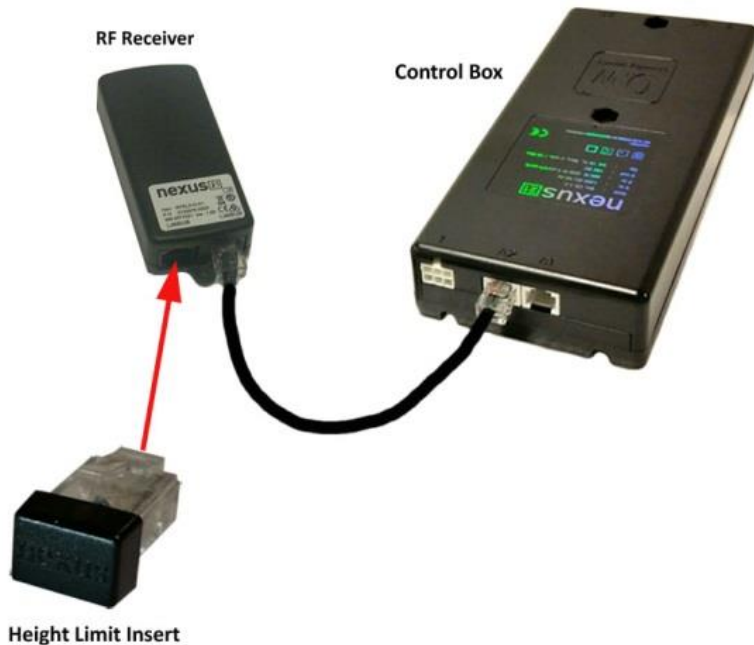

1. Using the Wired Backup Switch, run the lift system to the ideal height limit position and stop it there.

2. With the lift system stopped, plug the Height Limit Insert into the available RJ45 port on the RF Receiver. This will set the height limit at this position for both the RF Remote and Backup Switch.

3. If the height limit is set at the incorrect position, remove the Height Limit insert and repeat the procedure.

Supplemental Page C: Connect the Lift to Home Control System

Connecting the Nexus 21 Lift System to Other Control Systems

Use these instructions if you need to wire the Lift System directly to a Home Control System, like those made by Crestron, AMX, Control 4, RTI, etc. A common term for this method of integration is “connection by contact closure.”

Contents of Contact Closure Hardware Pack:

Step 1: Contact Closure Hardware Pack

This pack contains the following parts:

- 1 – Contact Closure Cable, RJ-45 to Relays
- 1 – Height limit Insert



Contact Closure Cable, RJ-45 to Relays



Height Limit Insert

Step 2: Connecting the Lift System to the Control System

Using the *Contact Closure Cable* to connect the three wires directly to the relays on your control module (see image below). Then connect the RJ-45 plug on the *Contact Closure Cable* to the Nexus 21 system, using either one of the two RJ-45 ports on the side of the Nexus 21 Control Box.

The colored wires function as follows:

BLUE = common (Pin 4 from RJ45) **GREEN** = Extend (Pin 5 from RJ45) **RED** = Retract (Pin 8 from RJ45)

Wire combinations for the relays:

The lift system uses two relays. One for “extend” and one for “retract.” The common wire runs between both relays, by using the **BLUE common wire**, together with a jumper wire you supply.

Relay 1 Extend: **BLUE** common wire with **GREEN** normally open.

Relay 2 Retract: **BLUE** common wire (use jumper) with **RED** normally open.



Close-up View of RJ-45 Pins

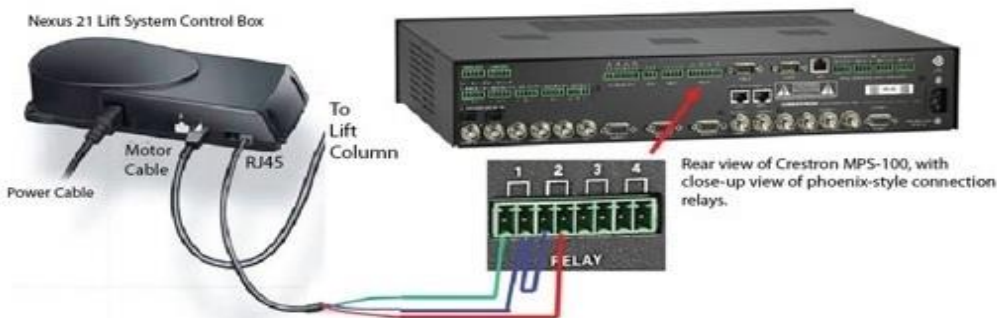

Step 3: Setting a Height Limit for the Lift System

Begin with the Height Limit Insert UNPLUGGED. Then send the “UP” command from your control system and run the Lift System up to your desired height. Once the Lift System is at the desired height, send the “DOWN” command to stop the lift at the point. Now PLUG the Height Limit Insert into the available RJ45 port on the Nexus 21 Control Box. The Lift will now remember the height and always stop at that point. To change, unplug the Height Limit Insert and repeat Step 3.

For technical support or to ask questions, call Nexus 21 Customer Service, toll-free at (866) 500-5438.

Supplemental Page D: Creating a Lid Catch

How to Properly Install a Lid "Catch" with a Nexus 21 Lift System

There are multiple ways to properly create a "catch" for the lid to rest on, when the lift is fully retracted. Down below are a few examples.

Using the provided Lid Catch Brackets with (8) #10 x 3/4" THWS attach the brackets to each corner of the lid opening. This provide a support point for the lid to rest on while the lift is in the fully retracted position, assuring the lid is flush with the rest of the cabinetry every time.

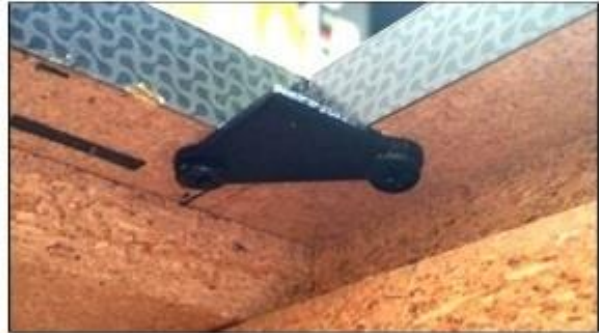

Here are a few other examples on how to properly create a "catch" for the cabinet lid.

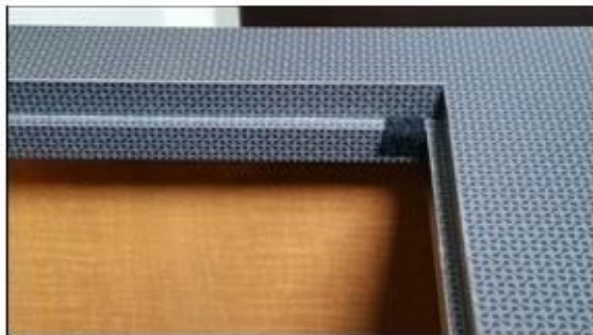

nexus 

CONCEALMENT SYSTEMS

866.500.5438