

MODEL L-45

FOR UP TO 65" TV

- Lift Extends 96.5 cm Upwards
- TV Maximum Screen Size: 65"
- TV Maximum Height: 94 cm
- Maximum Weight: 45.4 kg

Model L-45 combines flawless reliability with precision engineering to give you the perfect entertainment experience. Hide anything from a 40" TV at the foot of your bed to a 65" TV in a living room cabinet, all at the push of a single button.

- Near Silent Operation
- Easy to Install
- Remote Control Included
- Popular in Furniture, Living Rooms and Foot of the Bed Applications



All Nexus products are shipped in custom-made protective packaging, and they include everything you need to mount and operate them. The products are designed for easy assembly and simple instructions with photos are included.

MODEL L-45

TECHNICAL SPECIFICATIONS

- 45.4 kg total lift capacity
- TV maximum screen size: 65"
- Travels 96.5 cm
- No exposed tracks, gears or scissors
- UL recognized
- Draws 3.5 Amps @ 110V and 1.75 Amps @ 220V at max thrust
- Speed 3.8 cm / sec. (only 25 seconds to fully raise)
- Quiet - runs at just 45 dB
- Screw-driven mechanism
- Steel construction
- Your choice of RF remote or Control System Integration Kit (CSI Kit includes IR remote and contact closure interface)
- Exclusive Nexus 21 Safety Package included
- "Soft Start" and "Soft Stop" for smooth ride
- Power is Available in These Formats:
USA, 110V / Europe, 230V / Japan, 100V
Australia, 240V / UK, 230V

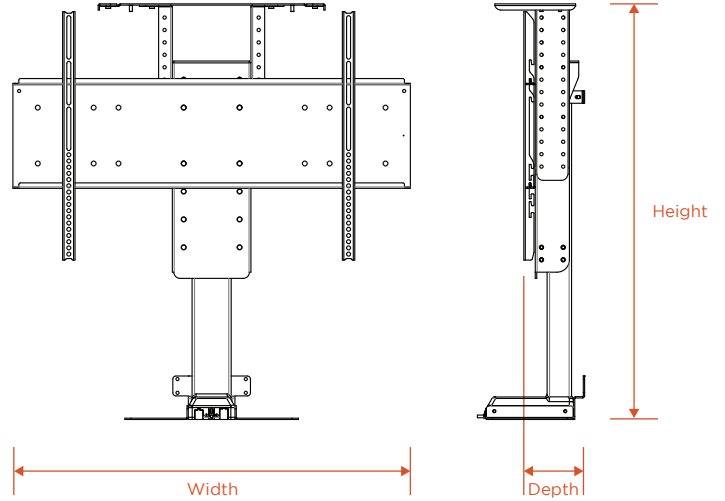

Height: 74.7 cm Min / 95 cm Max / Adjustable in 1.3 cm increments
Width: 81.3 cm
Depth: 12.4 cm from back wall to rear of TV

WHAT'S IN THE BOX

- Motorized lift column (the motorized unit is pre-assembled and ready to use)
- Heavy duty screen support with universal TV mounting plate
- Height adjustable top supports
- Top plate with adjustable extensions and finger safety
- Upper and lower back mounting brackets
- Control box with power cord
- Remote control and receiver (your choice of RF or CSI Kit*)
- Backup control switch
- Cord control wrap
- All hardware for assembly and mounting
- Full assembly instructions with photos



CONTROL OPTIONS

Your choice of RF remote or Control System Integration Kit (CSI Kit*). Wired button pad included with both.



*CSI Kit includes IR remote and contact closure interface

COMPATIBLE LID STYLES

Mounting bracket for floating lid included (our standard option) or purchase guides for a hinged lid version. Built-in finger safety system included.

