

MODEL L-50ens

POP-UP SWIVEL ENCLOSURE TV LIFT

For Up to 60" TV

TV Maximum Screen Size _____ 60"
Maximum Weight _____ 100 lbs

Model L-50ens is perfect for situations when the backside of the television is exposed, like at the foot of the bed or in a half wall. The lift and bracket system allow you to place an enclosure around the television that will seamlessly integrate the TV into the decor of the room. The smooth manual swivel function enables you to face the TV in any direction, creating the ideal viewing angle (enclosure itself is not included).

- Near Silent Operation
- Manual Swivel with Safety Cutoff
- Remote Control Included
- Popular in Applications Where Back of TV is Exposed

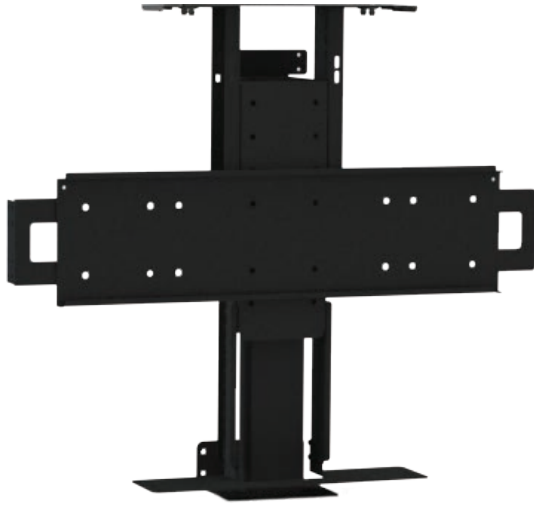

Nexus 21 solutions come complete with everything required for assembly and installation. Motorized systems are covered by a 10-year warranty and all products are backed by our world-class product support team.

MODEL L-50ens

TECHNICAL SPECIFICATIONS

- 100 lbs total lift capacity
- TV maximum screen size: 60"
- 360-degree manual swivel mechanism built-in (swivel function is operated manually)
- Travels 39.25"
- No exposed tracks, gears or scissors
- Draws 3.5 Amps @ 110V and 1.75 Amps @ 220V at max thrust
- Speed 1.5" / sec. (only 25 seconds to fully raise)
- Quiet - runs at just 45 dB
- Screw-driven mechanism
- Steel construction
- Your choice of RF remote or Control System Integration Kit (CSI Kit includes IR remote and contact closure interface)
- Exclusive Nexus 21 Safety Package included
- "Soft Start" and "Soft Stop" for smooth ride
- Power is available in these formats: USA, 110V / Europe, 230V / Japan, 100V / Australia, 240V / UK, 230V

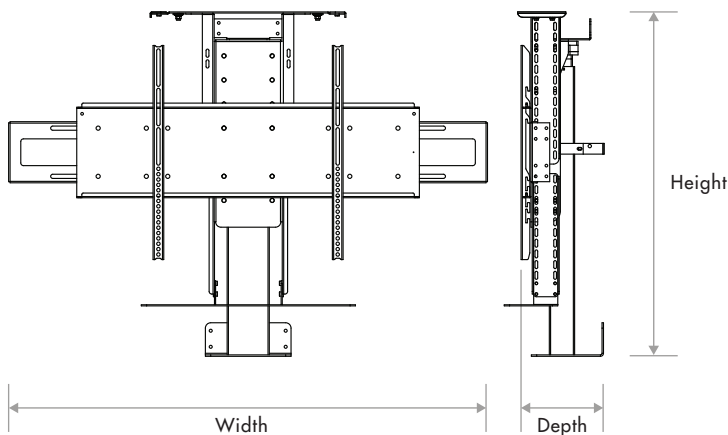

Height: 32.25" Min / 40.25" Max
Adjustable in 1/4" increments
Width: 37.75" Min / 54.625" Max
Depth: 7.75" from back wall to back of TV

WHAT'S IN THE BOX

- Motorized lift column (the motorized unit is pre-assembled and ready to use)
- Manual swivel mechanism with electronic safety switch
- Heavy duty screen support with universal TV mounting plate
- Height adjustable top supports
- Universal mounting brackets for TV enclosure (enclosure itself is not provided)
- Top plate with adjustable extensions and finger safety
- Upper and lower back mounting brackets
- Control box with power cord
- Remote control and receiver (your choice of RF or CSI Kit*)
- Backup control switch
- Cord control wrap
- All hardware for assembly and mounting
- Full assembly instructions with photos

CONTROL OPTIONS

Your choice of RF remote or Control System Integration Kit (CSI Kit*). Wired button pad included with both.



*CSI Kit includes IR remote and contact closure interface

SWIVEL VERSION

360-degree manual swivel mechanism built-in. Mounting bracket for floating lid with built-in finger safety system is included.

