



MODEL L-75i

FOR UP TO 75" TV

- Lift Extends 132 cm Downwards
- TV Maximum Screen Size: 75"
- Maximum Weight: 45.4 kg

Model L-75i converts any room into a custom movie theater by smoothly lowering large TV screens into view at the push of a button. Precision-engineered for ease of installation and superior reliability, this lift has been installed in more luxury homes, government facilities and royal palaces than any other mechanism.

- Industry-Leading Reliability
- Near Silent Operation
- Includes Mounting Kit for Your Ceiling Cover
- Popular for Hiding TVs in the Ceiling



All Nexus products are shipped in custom-made protective packaging, and they include everything you need to mount and operate them. The products are designed for easy assembly and simple instructions with photos are included.

MODEL L-75i

TECHNICAL SPECIFICATIONS

- 45.4 kg total lift capacity
- TV maximum screen size: 75"
- Travels 132 cm
- No exposed tracks, gears or scissors
- UL recognized
- Draws 3.5 Amps @ 110V and 1.75 Amps @ 220V at max thrust
- Speed 8.9 cm /sec. (only 15 seconds to fully raise)
- Quiet - runs at just 45 dB
- Chain-driven mechanism
- Steel construction
- Your choice of RF remote or Control System Integration Kit (CSI Kit includes IR remote and contact closure interface)
- Exclusive Nexus 21 Safety Package included
- "Soft Start" and "Soft Stop" for smooth ride
- Professional Installation Required
- Power is Available in These Formats:
USA, 110V / Europe, 230V / Japan, 100V
Australia, 240V / UK, 230V

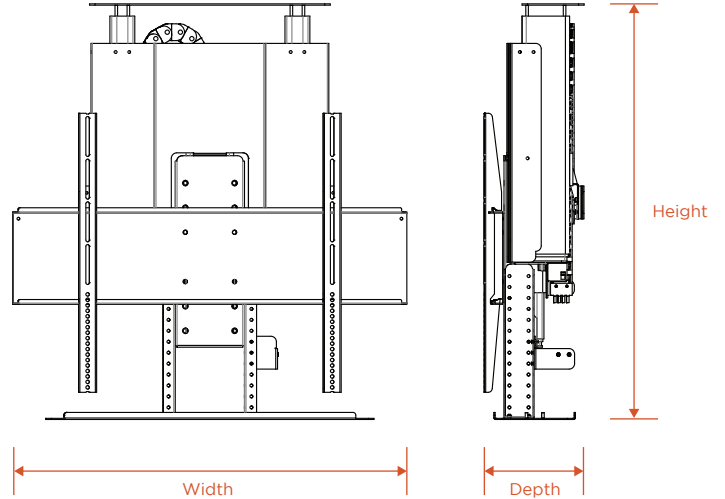

Height: 79 cm Min / 99.3 cm Max
Width: 91.4 cm
Depth: 22.6 cm

WHAT'S IN THE BOX

- Motorized lift columns (the motorized units are pre-assembled and ready to use)
- Heavy duty screen support with universal TV mounting plate
- Height adjustable top supports
- Lid plate with stabilization hardware
- Base plates and upper back mounting brackets
- Control box with power cord
- Remote control and receiver (your choice of RF or CSI Kit*)
- Backup control switch
- Cord control wraps
- All hardware for assembly and mounting
- Full assembly instructions with photos



CONTROL OPTIONS

Your choice of RF remote or Control System Integration Kit (CSI Kit*). Wired button pad included with both.

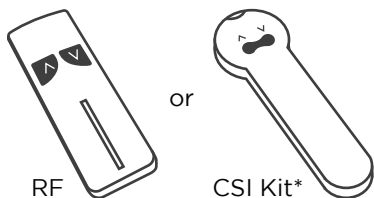

MOUNTING BRACKET FOR CEILING COVER

Attach any type of cover to the lid plate to seamlessly hide the lift within the ceiling or cabinet. Spring loaded lid stabilization hardware included.

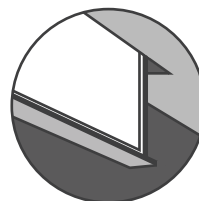

*CSI Kit includes IR remote and contact closure interface