

SANUS[™]
V U E P O I N T

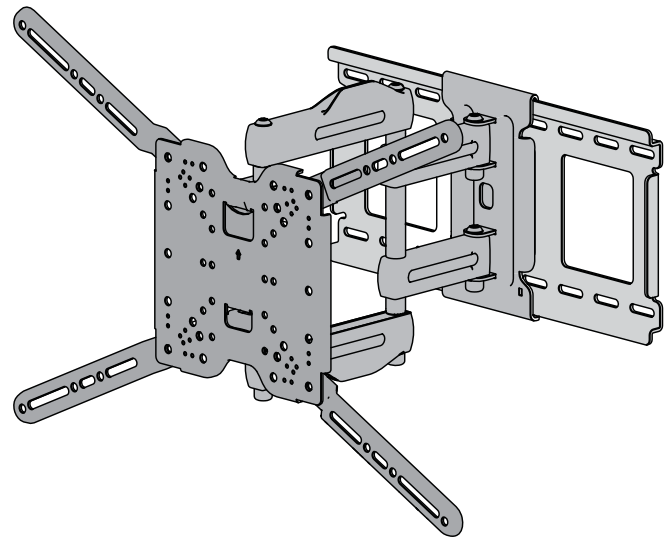

F180c INSTRUCTION MANUAL

We'll Make It Stress-Free

If you have any questions along the way, just give us a call.
1-888-333-9952. We're ready to help!

Scan for easy install video

san.us/794



IMPORTANT SAFETY INSTRUCTIONS – SAVE THESE INSTRUCTIONS – PLEASE READ ENTIRE MANUAL PRIOR TO USE

Before getting started, let's make sure this mount is perfect for you!

1 Does your TV weigh *more* than 100 lb (45.4 kg) including accessories?



No — Perfect!

Yes — This mount is NOT compatible. Visit vuepoint.sanus.com or call 1-888-333-9952 to find a compatible mount.

2 What is your wall made of?



Drywall with wood studs? Perfect!



Solid concrete or concrete block - call 1-888-333-9952



Unsure? Call 1-888-333-9952

3 Do you have all of the tools needed?

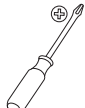
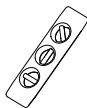
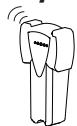

Optional



4 Ready to begin?

Please read through these instructions completely to be sure you're comfortable with this easy install process. Also check your TV owner's manual to see if there are any special requirements for mounting your TV.

If you do not understand these instructions or have doubts about the safety of the installation, assembly or use of this product, contact Customer Service at 1-888-333-9952.

▲ CAUTION: Avoid potential personal injuries and property damage!

- This product is designed for use in wood stud, solid concrete, and concrete block walls - DO NOT install into drywall alone
- The wall must be capable of supporting five times the weight of the TV and mount combined
- Do not use this product for any purpose not explicitly specified by manufacturer
- Manufacturer is not responsible for damage or injury caused by incorrect assembly or use

Dimensions

in.
[cm]

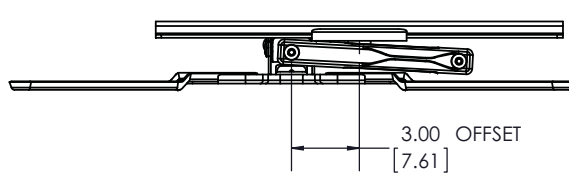
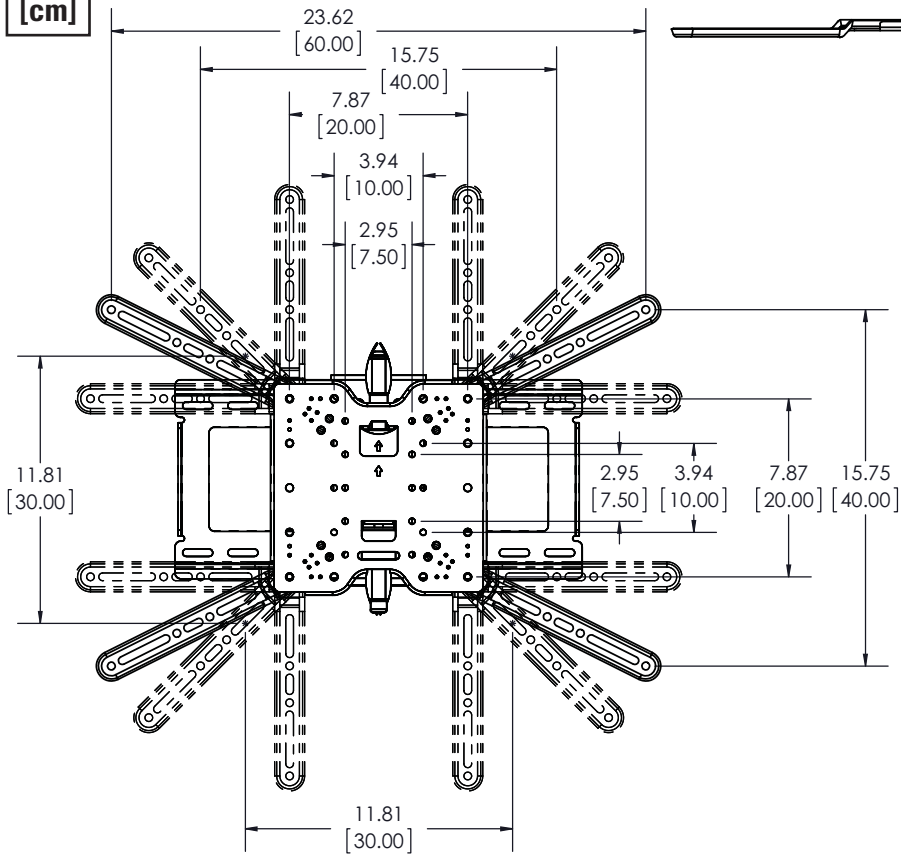

 **NOTE:** TV shifts 3 in. (7.61 cm) to the right or left when in the home position. Consider this when selecting the location of your wall mount.

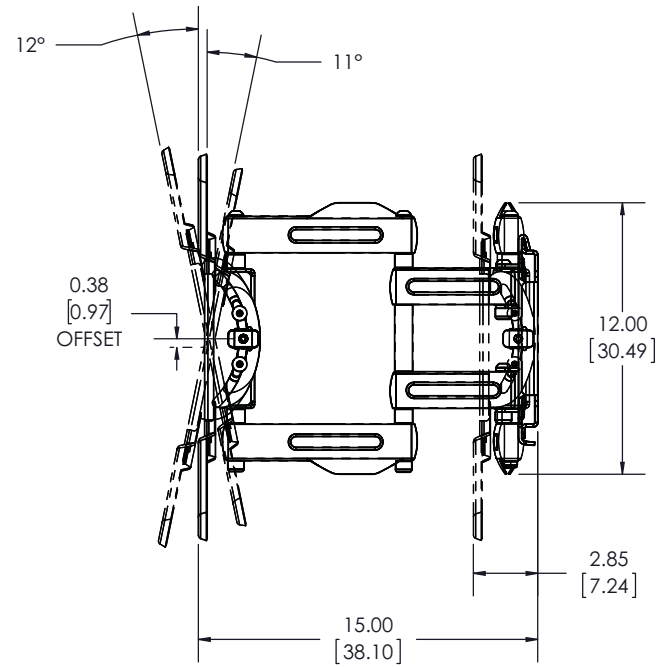

Supplied Parts and Hardware

⚠ WARNING: This product contains small items that could be a choking hazard if swallowed. Before starting assembly, verify all parts are included and undamaged. If any parts are missing or damaged, do not return the damaged item to your dealer; contact Customer Service. Never use damaged parts!

📄 NOTE: Not all hardware included will be used.

STEP 1 Parts and Hardware

TV Bracket

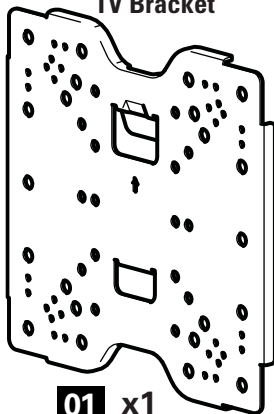

M8 x 12mm

TV Bracket Interface Screws

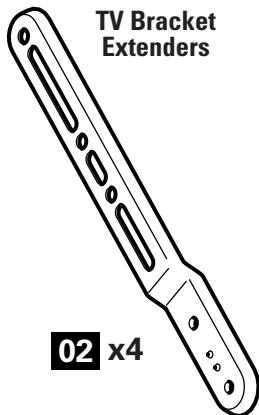

TV Bracket Extenders

Washers



M5



M6/M8

TV Screws

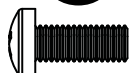

M5 x 12mm

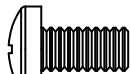

M6 x 12mm

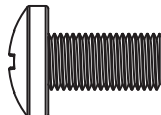

M8 x 16mm



M6 x 20mm

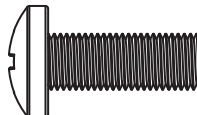

M8 x 20mm

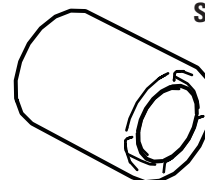

Spacers



M5 x 35mm



M6 x 35mm

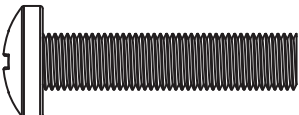

M8 x 35mm

STEP 2 Parts and Hardware

Wall Plate Template

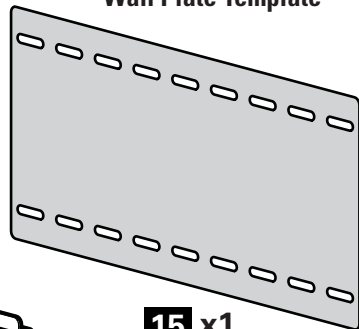

15 x1

Wall Plate

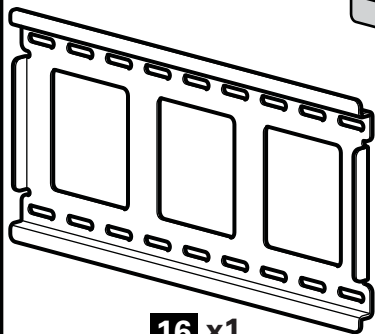

16 x1

Lag Bolt Washers

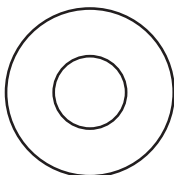

.695 x .350 x .075 in.

17 x4

Lag Bolts

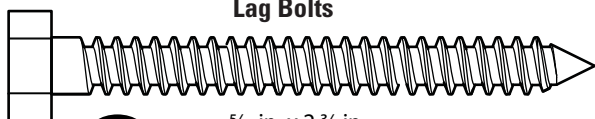

18 x4

$\frac{5}{16}$ in. x $2\frac{3}{4}$ in.

STEP 3 Parts and Hardware

Arm Assembly

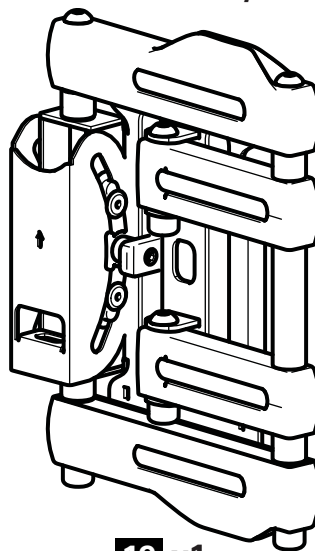

19 x1

Locking Screw

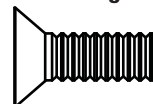

1/4-20 x 3/4 in.

20 x1

Safety Screw



10-24 x 1 in.

21 x2

Additional Hardware

Cable Ties



22 x5

Concrete Installation Kit CMK1 (NOT INCLUDED)

Contact Customer Service at 1-888-333-9952 to have these additional pieces shipped directly to you.

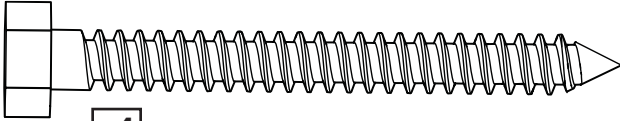

x4

5/16 x 2¾ in.



x4

.695 x .350 x .075 in.



x4

Fischer UX 10 x 60 Anchor

STEP 1 Attach TV Bracket to TV

1-1 Measure Your TV Hole Pattern

Measure the width and height of your TV hole pattern in cm.

Record your measurements:

Width _____ cm x Height _____ cm

75 mm = 7.5 cm \approx 3 in.
100 mm = 10 cm \approx 4 in.
200 mm = 20 cm \approx 7 7/8 in.
300 mm = 30 cm \approx 11 3/4 in.
400 mm = 40 cm \approx 15 3/4 in.

inch dimensions are approximate

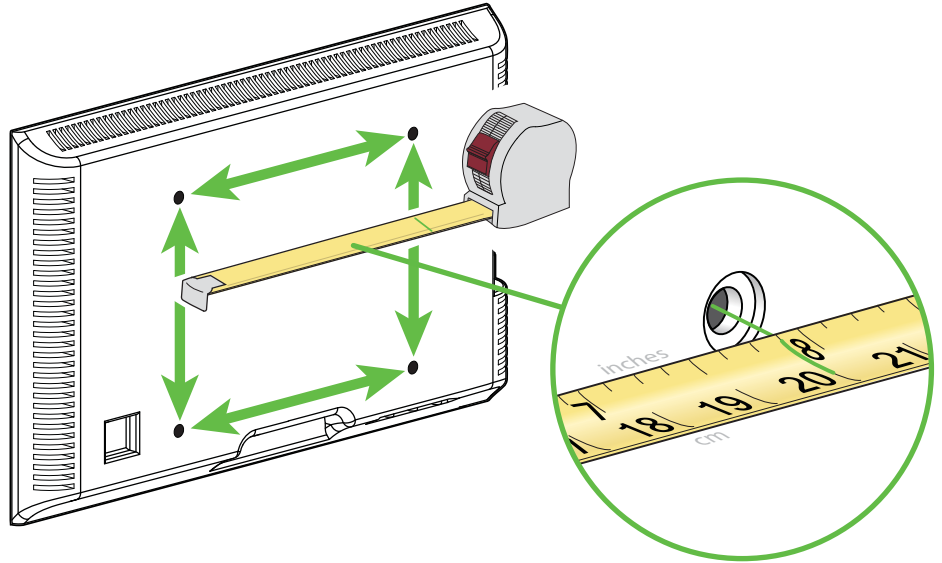

1-2 Assemble Your TV Bracket

Determine which TV bracket configuration to use, A, B, C, or D based on your TV hole pattern measurements.

A

7.5 x 7.5
10.0 x 10.0
20.0 x 20.0

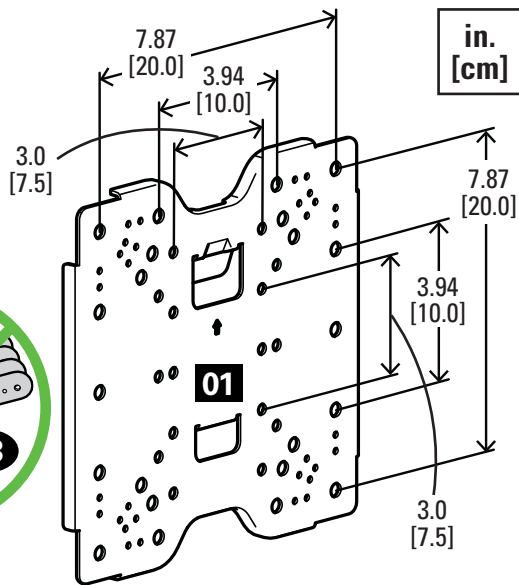

These smaller hole patterns only use TV bracket **01**.

Do not use the four TV bracket extenders **02** and eight screws **03**.

B

40.0 x 40.0

in.
[cm]

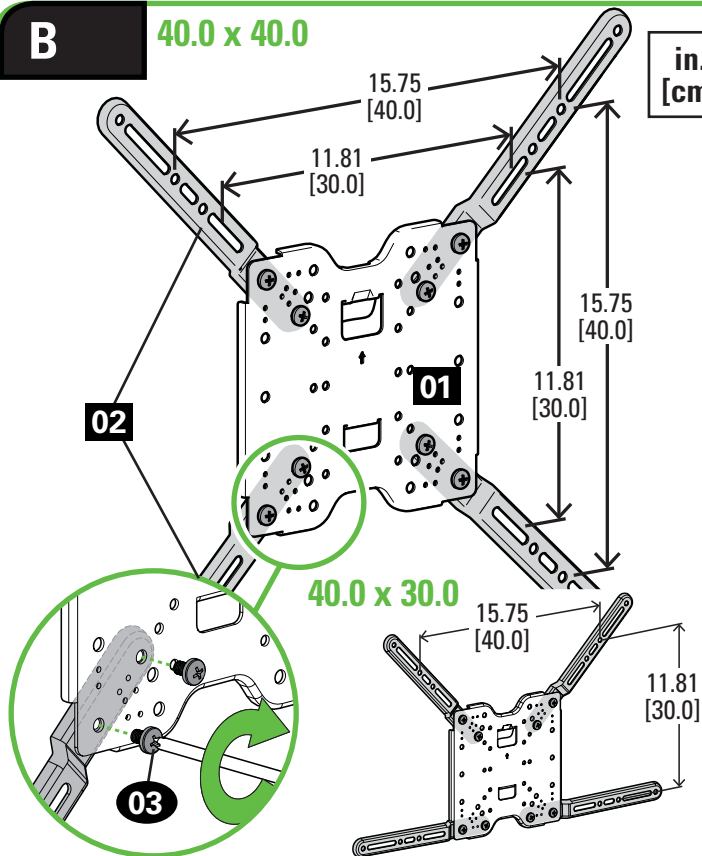

Assemble TV bracket extenders **02** onto TV bracket **01** as illustrated. Secure using eight screws **03** in the corner holes shown.

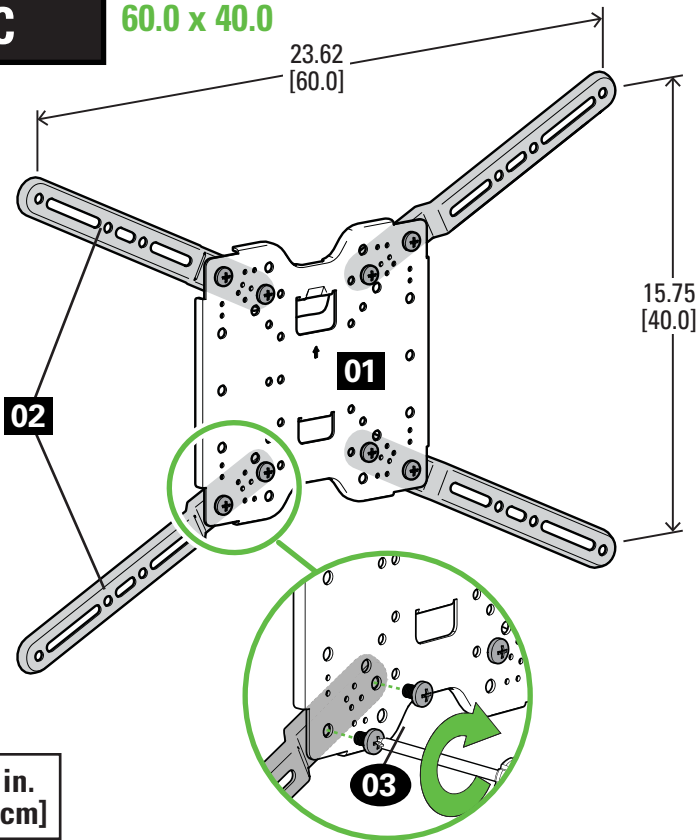
C**60.0 x 40.0**in.
[cm]

Assemble TV bracket extenders **02** onto TV bracket **01** as illustrated. Secure using eight screws **03** in the corner holes shown.

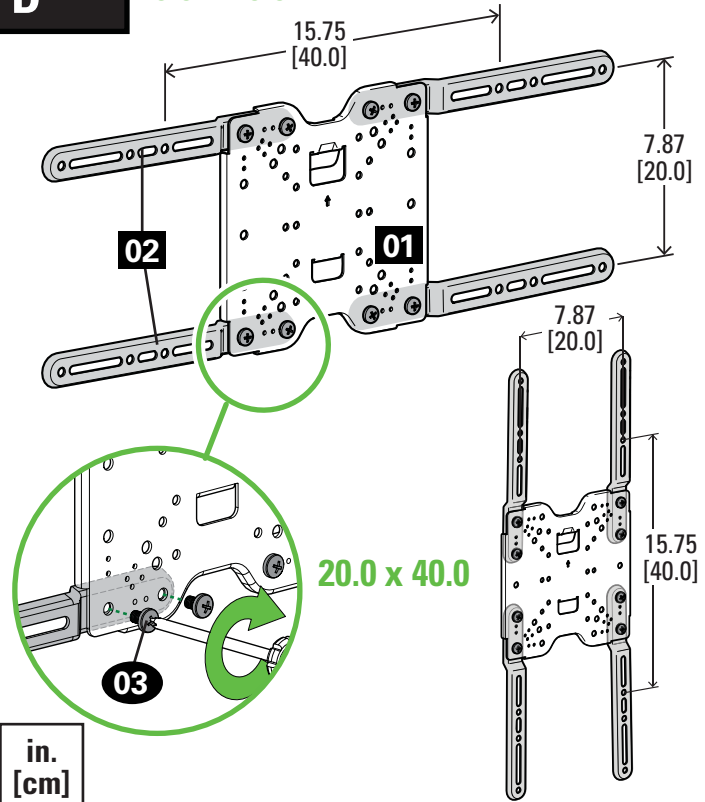
D**40.0 x 20.0**in.
[cm]

Assemble TV bracket extenders **02** onto TV bracket **01** as illustrated. Secure using eight screws **03** in the corner holes shown.

1-3 Select TV Screw Diameter

Hand thread screws into the threaded inserts on the back of your TV to determine which screw diameter (M5, M6, or M8) to use.

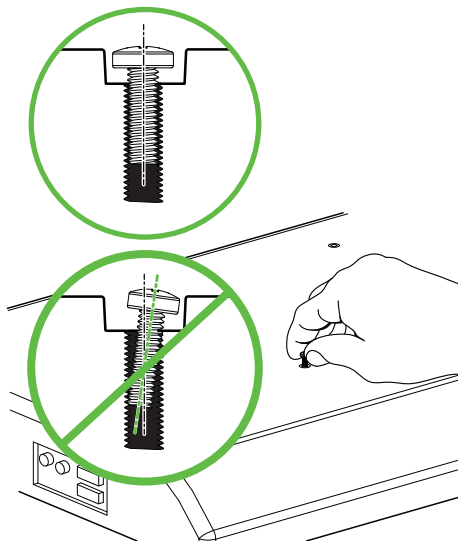

1-4 Select TV Screw Length

If your TV has a flat back AND you want your TV closer to the wall, use the shorter screws.

Spacers and longer screws are supplied to accommodate:

- Round/irregular back TVs
- TVs with inset mounting holes
- Extra space needed for cables

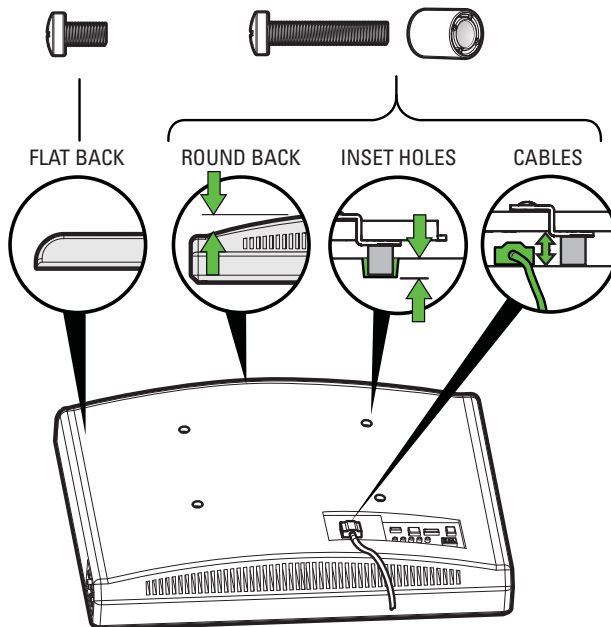

Standard configurations are shown. For special applications, or if you are uncertain about your hardware selection, contact Customer Service at 1-888-333-9952.

⚠ CAUTION:

Verify adequate thread engagement with the screw or screw/spacer combination.

- Too short will not hold the TV.
- Too long will damage the TV.

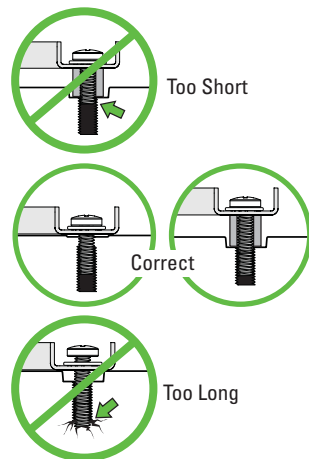

1-5 Attach TV Bracket

Position your TV bracket configuration (A, B, C, or D) over your TV hole pattern - making sure the bracket is centered over the TV hole pattern and level. Secure bracket using your screw/washer (**Flat Back**) or spacer/screw/washer (**Round Back / Extra Space**) selection.

IMPORTANT: Ensure TV bracket is securely fastened before moving on to the next step.

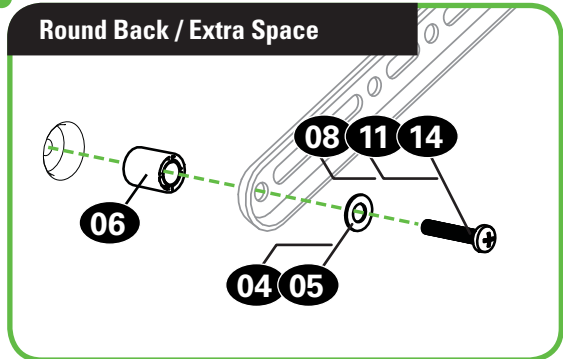
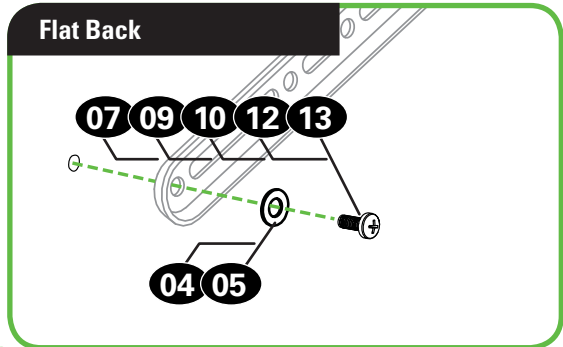
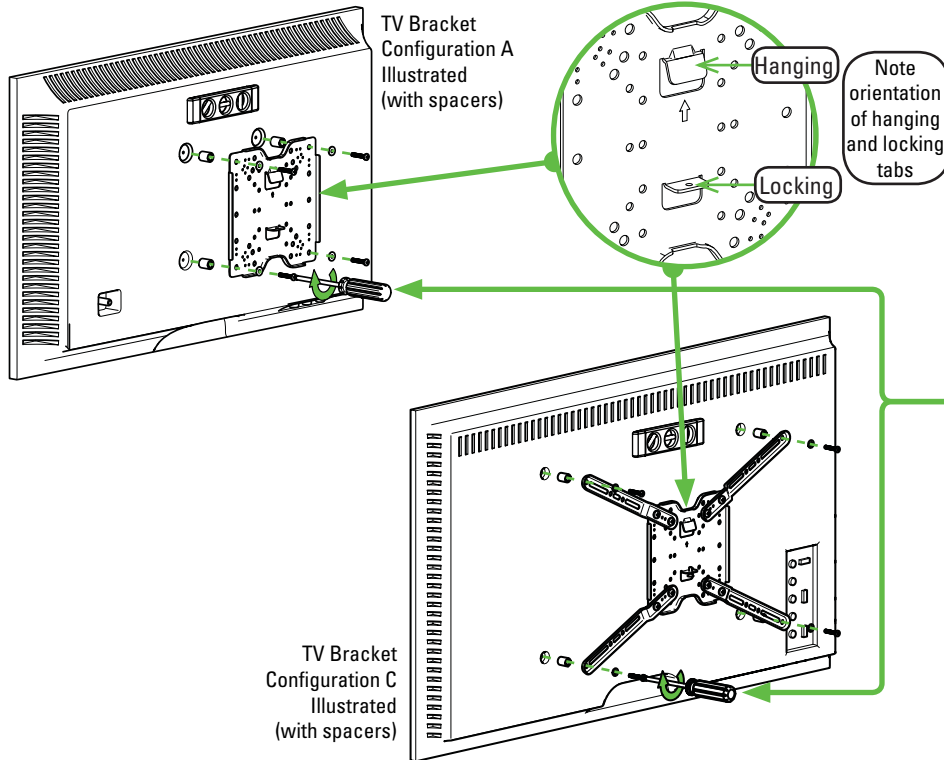

STEP 2A Attach Wall Plate to Wall

Wood Stud Option

⚠ CAUTION: Avoid potential personal injuries and property damage!

- Drywall covering the wall must not exceed 5/8 in. (16 mm)
- Minimum wood stud size: common 2 x 4 in. (51 x 102 mm) nominal 1½ x 3½ in. (38 x 89 mm)

1. Locate your stud. Verify and mark the center of the stud by finding the stud edges using an awl, a thin nail, or an edge-to-edge stud finder.
2. Position the wall template **15** at your desired height and line up the holes with your stud center line. Level the template and tape in place.

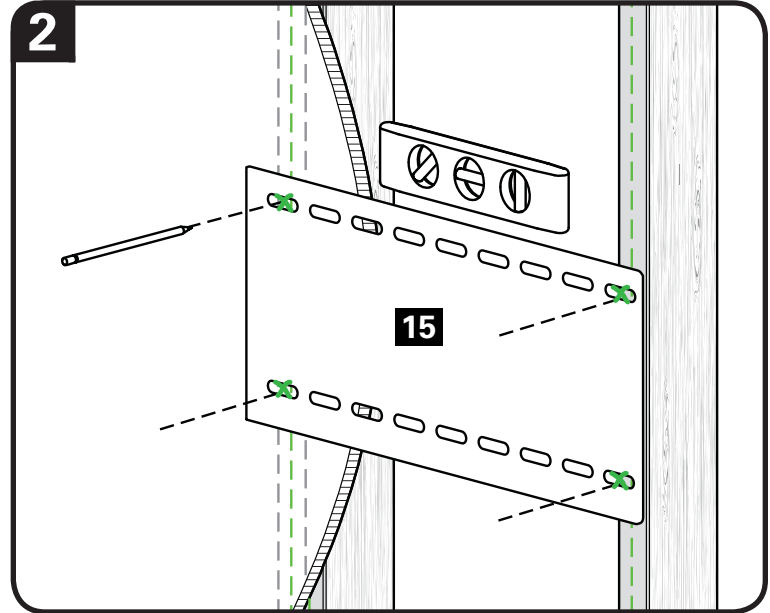
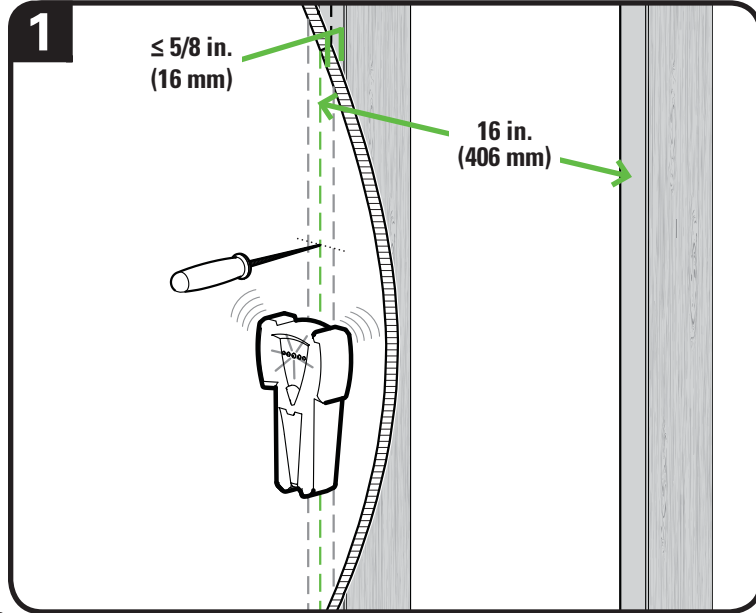

3. Drill pilot holes using a 7/32 in. (5.5 mm) diameter drill bit. Remove wall plate template **15**.

⚠ **IMPORTANT:** Be sure to drill into the center of the stud.

⚠ **IMPORTANT:** Pilot holes must be drilled to a depth of 3 in. (75 mm).

4. Install wall plate **16** using lag bolts **18**. Tighten the lag bolts **18** only until the washers **17** are pulled firmly against the wall plate **16**.

⚠ **CAUTION:** Improper use could reduce the holding power of the lag bolt. **DO NOT over-tighten the lag bolts.**

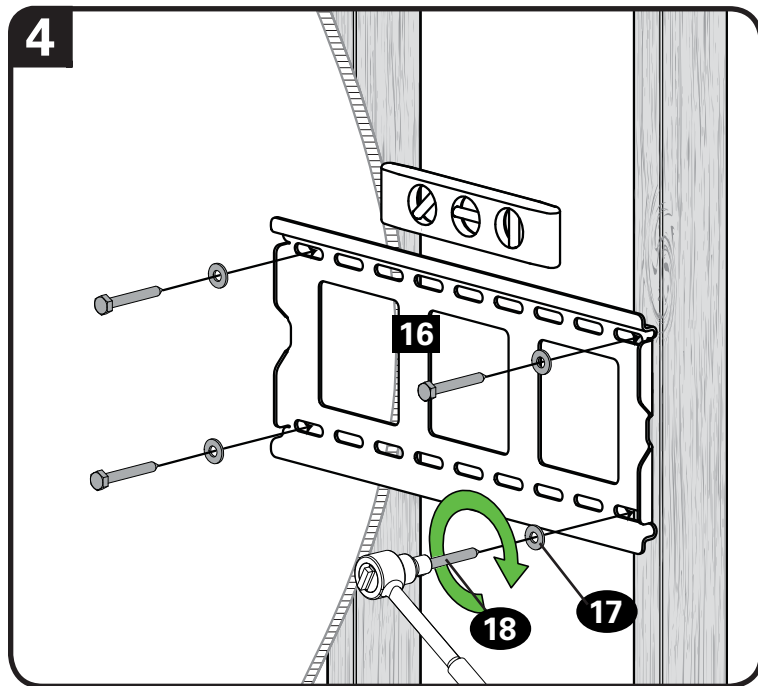
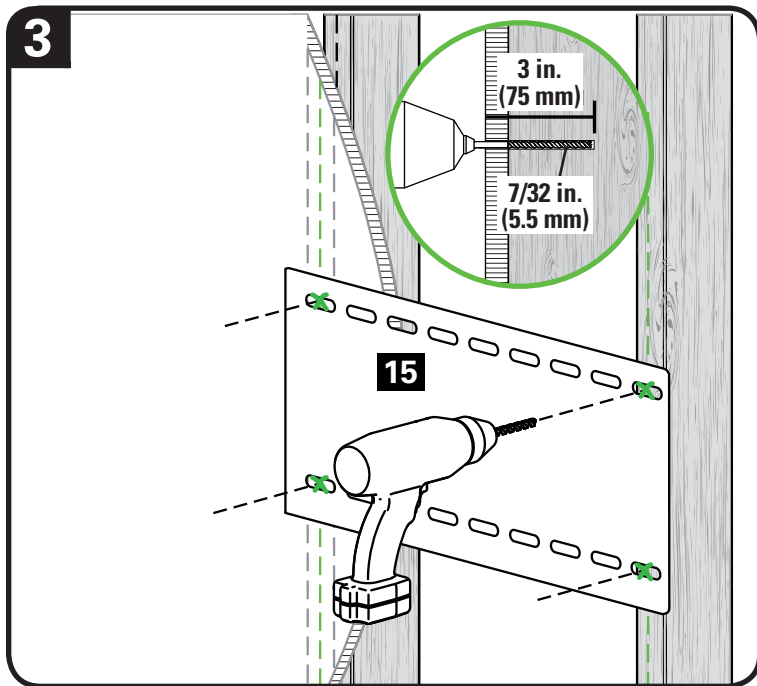

STEP 2B Attach Wall Plate to Wall

Solid Concrete or Concrete Block Option

CAUTION: Avoid potential personal injuries and property damage!

- Mount the wall plate **16** directly onto the concrete surface
- Minimum solid concrete thickness: 8 in. (203 mm)
- Minimum concrete block size: 8 x 8 x 16 in. (203 x 203 x 406 mm)
- Minimum horizontal space between fasteners: 16 in. (406 mm)

1. Position the wall plate template **15** on the wall at your desired height. Level the wall plate template and mark the hole locations.
2. Drill three pilot holes using a 3/8 in. (10 mm) diameter masonry drill bit.

! IMPORTANT: Pilot holes must be drilled to a depth of 3 in. (75 mm). Never drill into the mortar between blocks.

Concrete Installation Kit CMK1 is not included

(see page 6) Contact Customer Service at 1-888-333-9952 to have the additional hardware shipped directly to you.

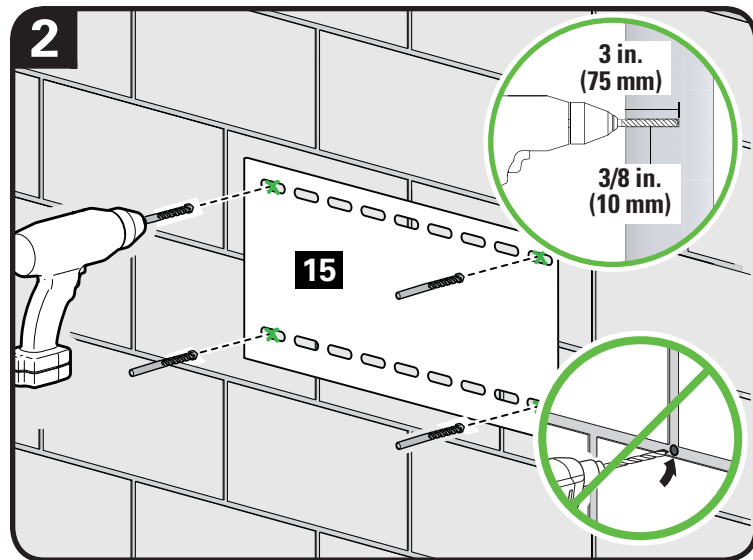
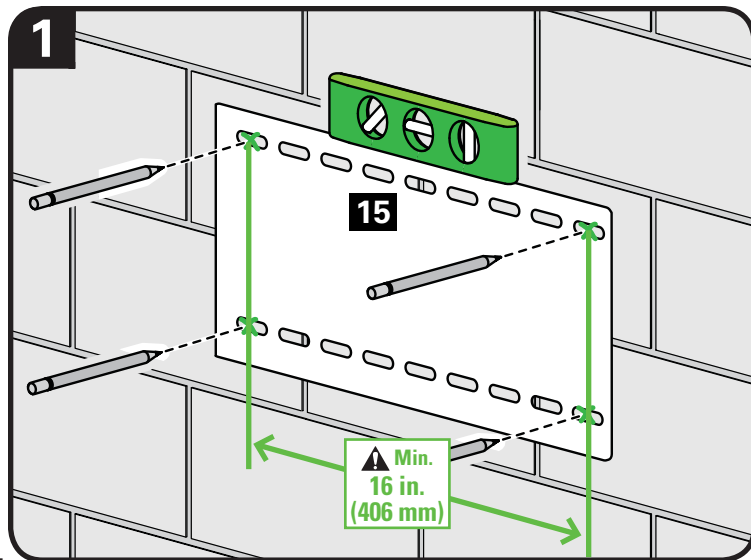

3. Remove the wall plate template **15** and insert four anchors (Fischer UX 10 x 60 - included in the [Concrete Installation Kit*](#)).

⚠ CAUTION: Be sure the anchors are seated flush with the concrete surface.

4. Install wall plate **16** using four lag bolts and four washers (use **only** the lag bolts and washers from the [Concrete Installation Kit*](#)). Tighten the lag bolts only until the washers are pulled firmly against the wall plate.

⚠ CAUTION: Improper use could reduce the holding power of the lag bolt. DO NOT over-tighten the lag bolts.

*Contact Customer Service at 1-888-333-9952 to have the [Concrete Installation Kit](#) shipped directly to you.

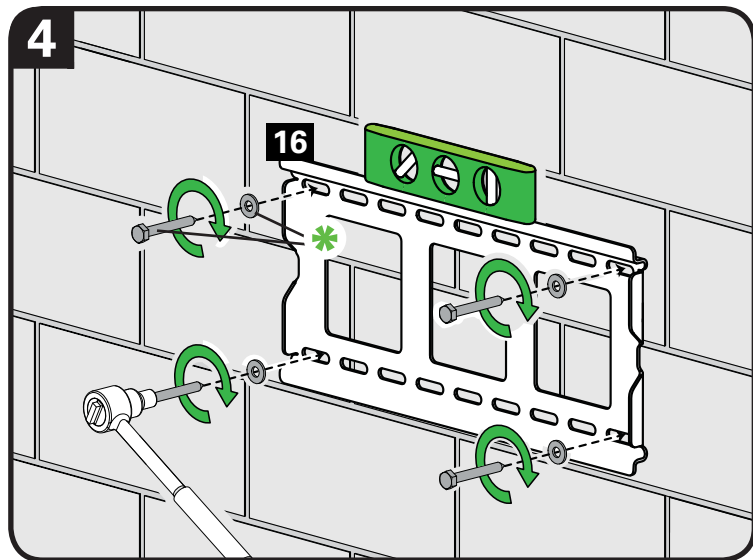
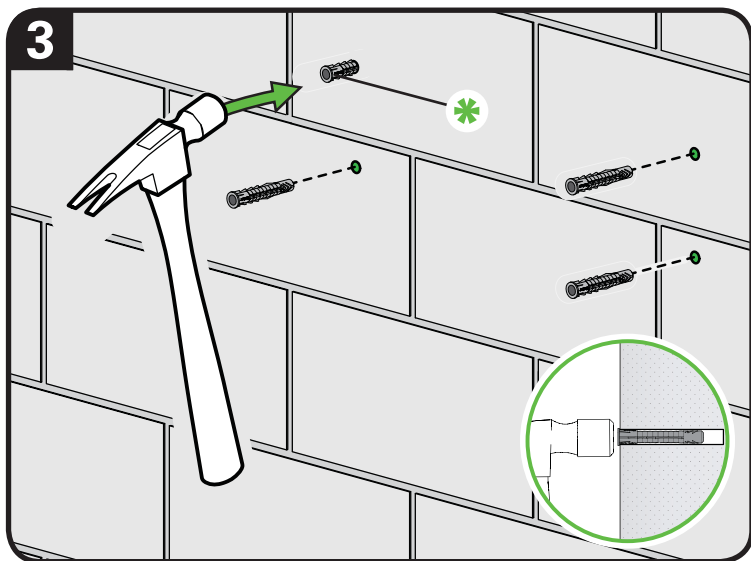

STEP 3 Attach TV to Wall Plate



HEAVY! You may need assistance with this step.

1. Hang the arm **19** onto the wall plate **16** by first hooking the top support, then resting the arm **19** into place.
2. Install locking screws **21** to secure arm to wall plate **16**.

 **NOTE:** Arm **19** can slide side-to-side along the wall plate **16** for perfect positioning.

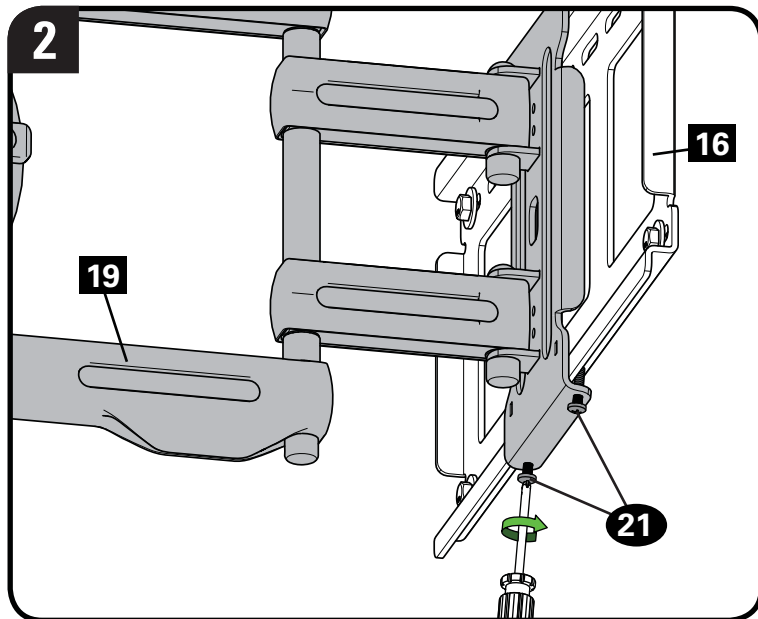
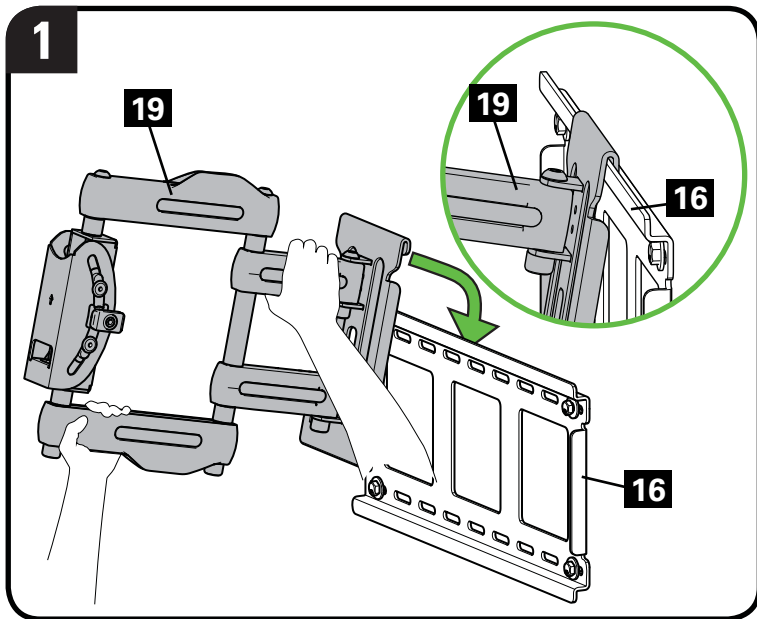
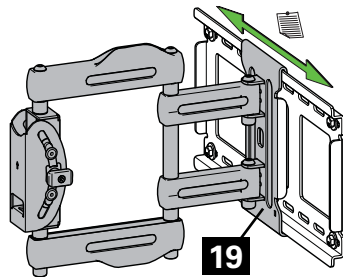



HEAVY! You may need assistance with this step.

3. Fold first section of the arm **19** against the wall plate **16** to provide stability.
4. Hang the TV bracket **01** onto the arm **19** by first hooking the top support, then resting the TV into place.

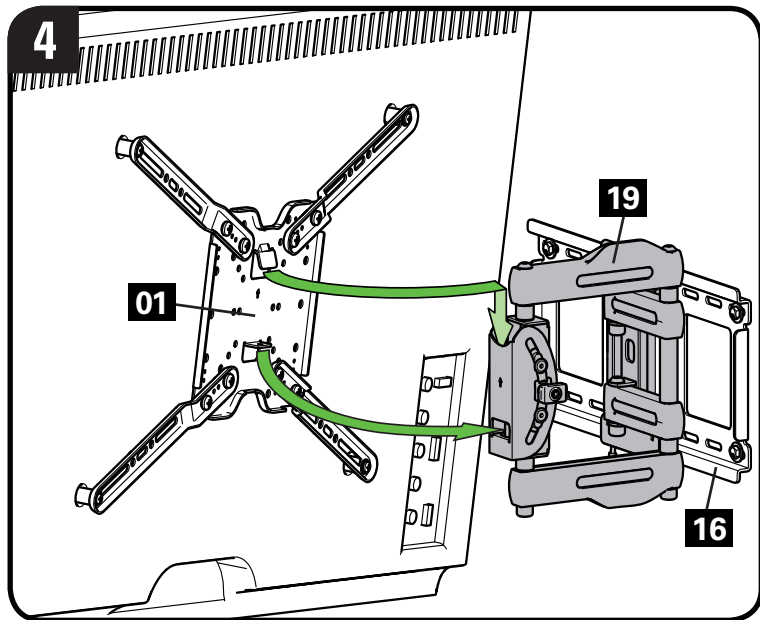
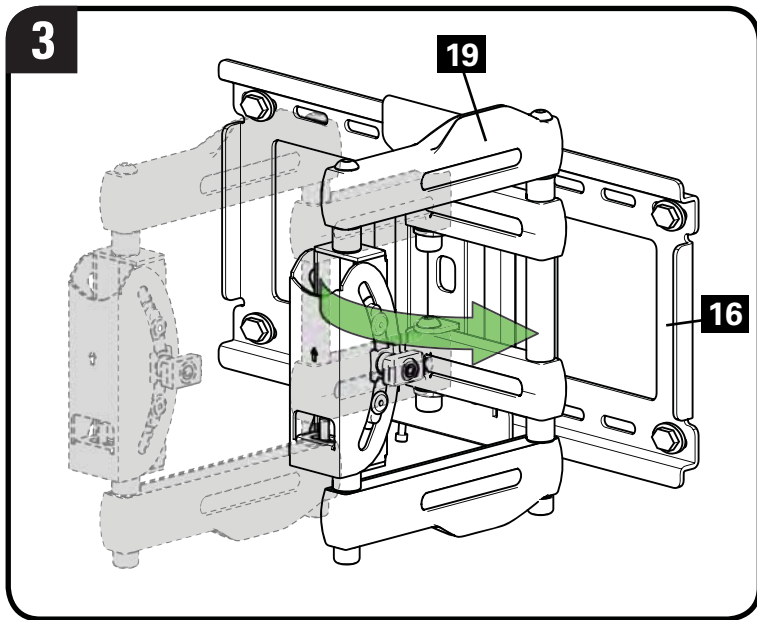

5. Lock the TV bracket **01** to the arm **19** with safety screw **20**.

! IMPORTANT: This safety screw **20** **must** be installed to secure the TV bracket **01** onto the arm **19**.

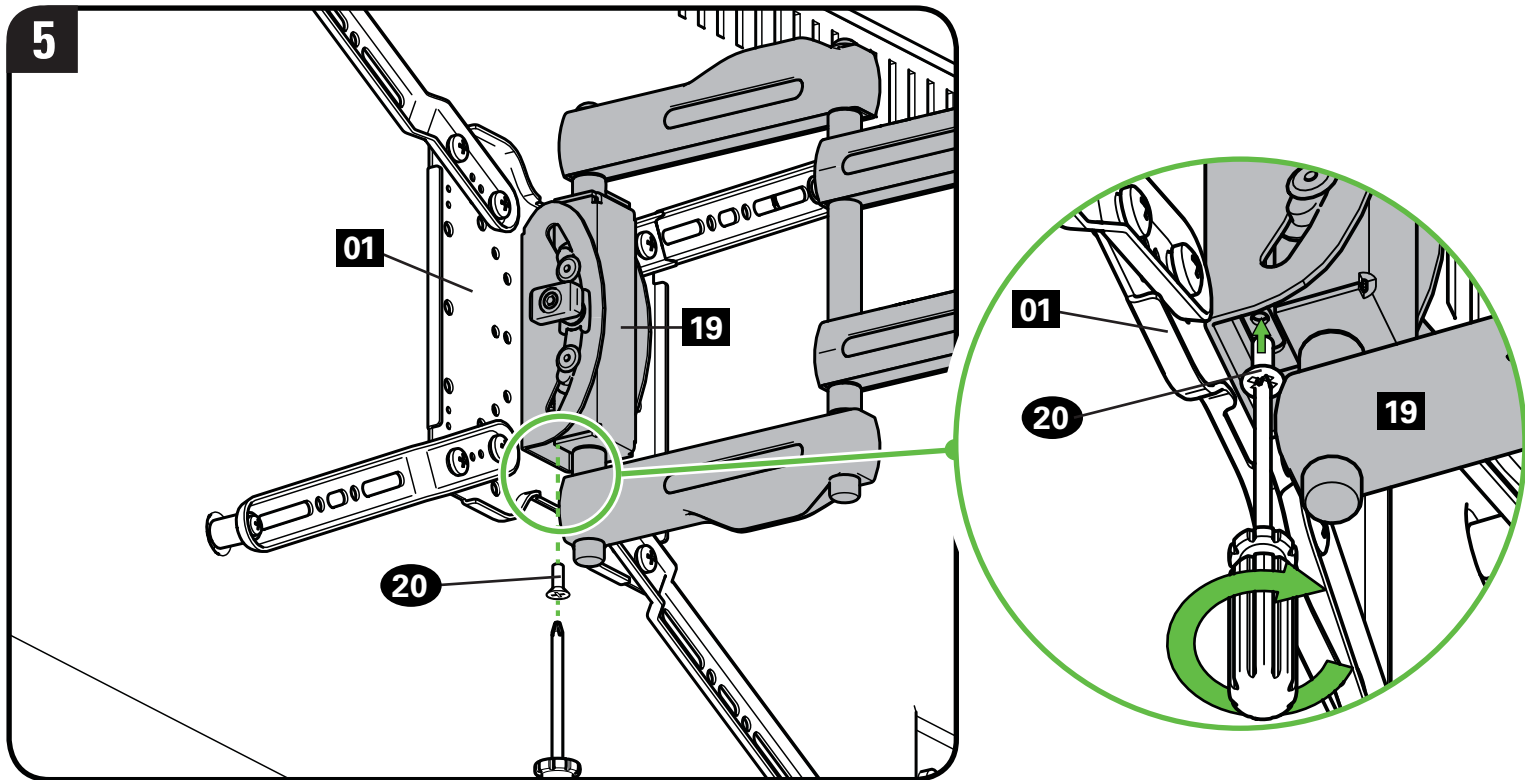

Manage Cables

Cables can be routed through the cable channels on the top and bottom of the arm **19** and secured to the arm with zip ties **22** for a cleaner look.

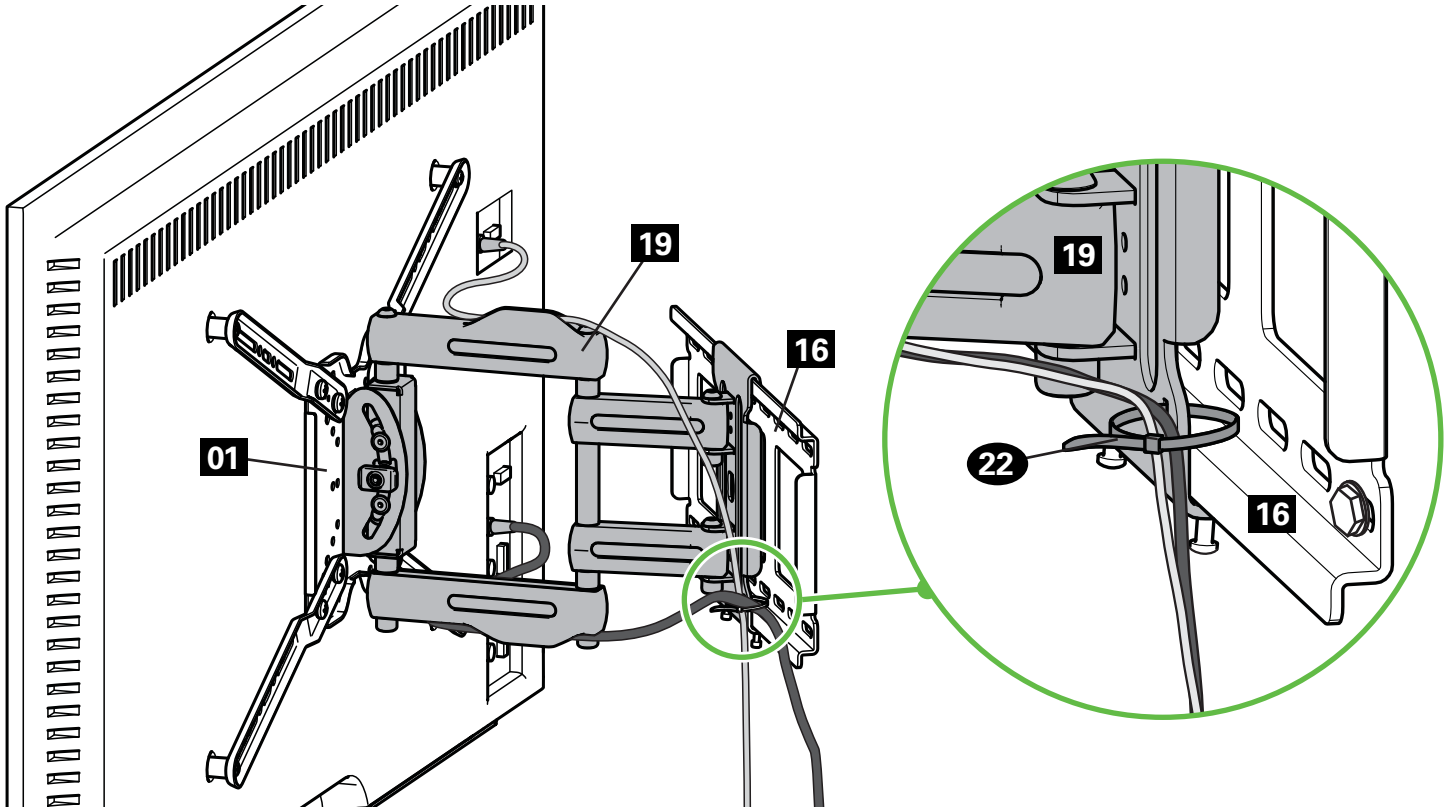

TV Adjustments

TILT ADJUSTMENT

Your TV should adjust easily when moved, then stay in place.

If your TV is too loose or too tight, adjust the tilt tension knob by hand.

NOTE: Once your TV is in place, tighten the tilt tension knob to prevent unwanted movement.

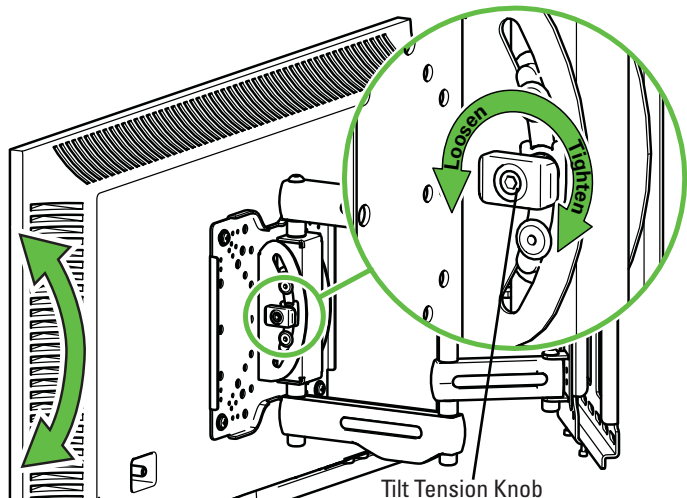

Tilt Tension Knob

LEVEL ADJUSTMENT

To adjust the leveling of your TV, loosen the safety screw **20**, level your TV, then tighten safety screw **20**.

IMPORTANT: This safety screw **20** must be installed to secure the TV onto the arm **19**.

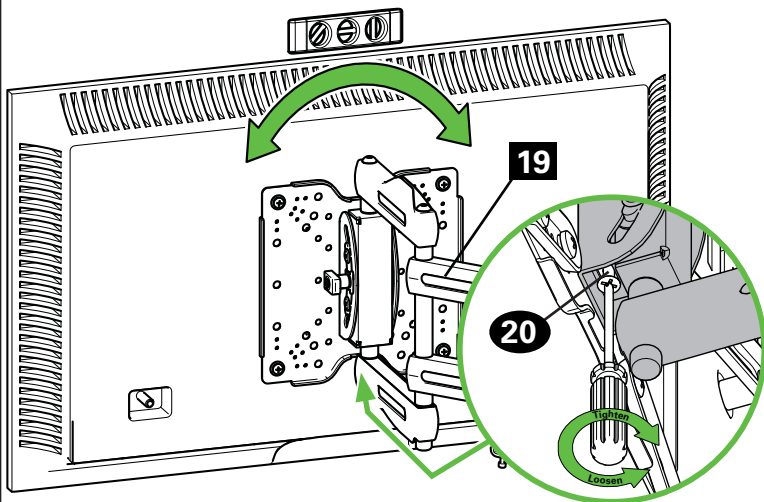

REMOVING THE TV



HEAVY! You may need assistance with this step.

To remove your TV from the arm assembly **19**, disconnect all cables and then reverse the procedures in **STEP 3**.

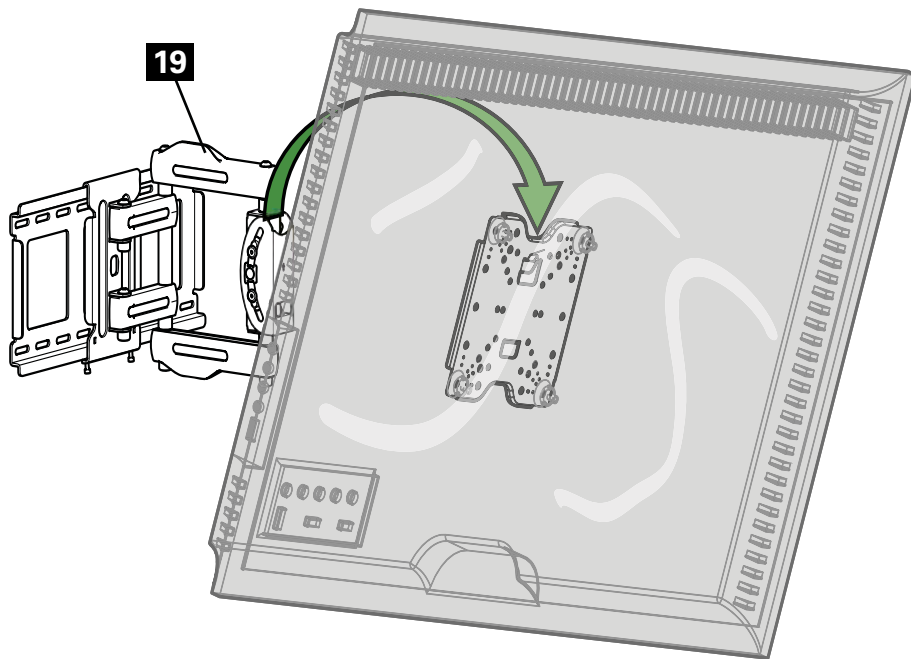

Features

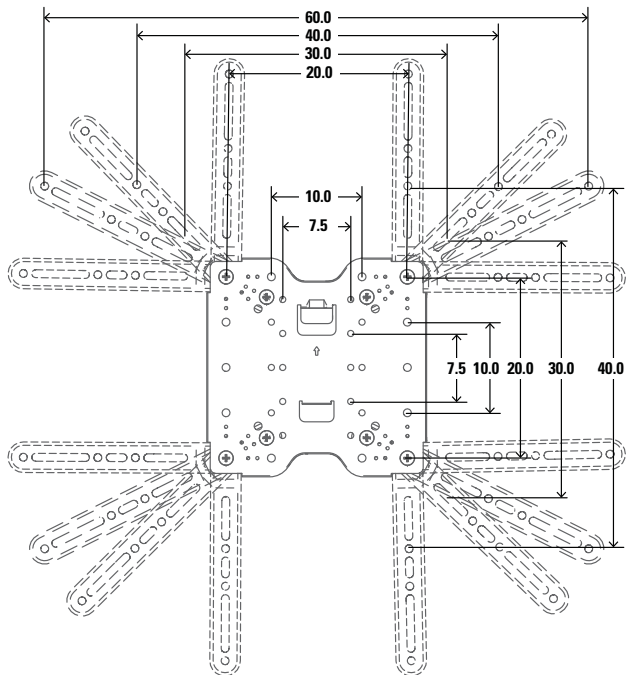

TV bracket can be configured to fit TV hole patterns from 7.5 x 7.5 cm up to 60.0 x 40.0 cm

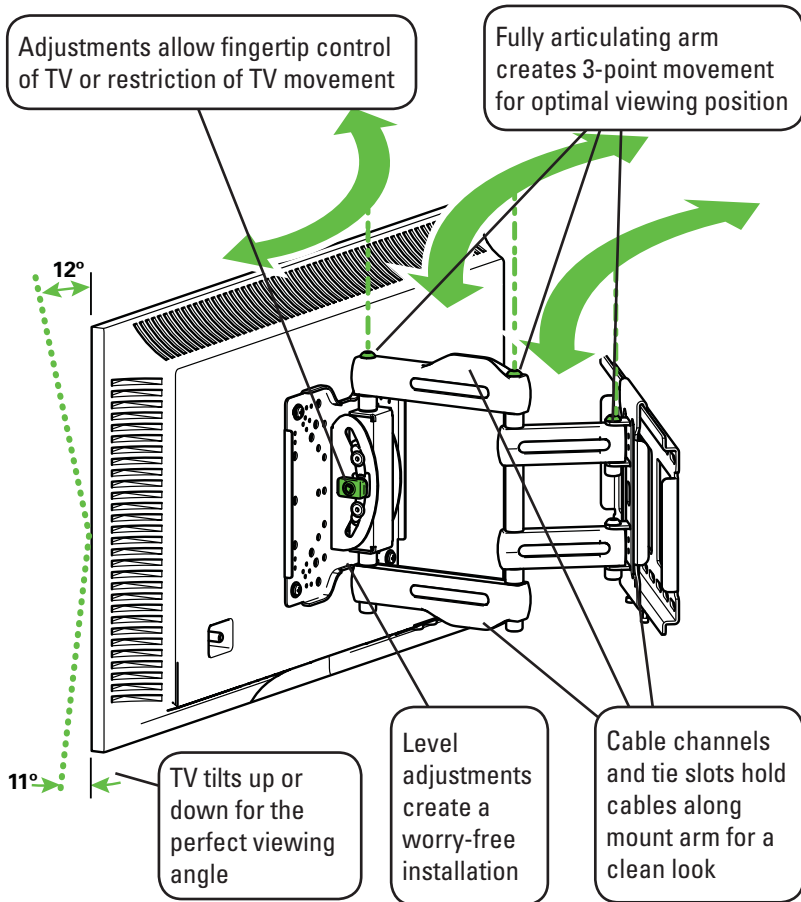

Antes de comenzar, verifiquemos que este soporte sea perfecto para usted.

1

¿Su televisor pesa *más* de 45.4 kg (100 libras), incluidos los accesorios?



No — ¡Perfecto!

Sí — Este soporte NO es compatible. Visite Vuepoint.Sanus.com o llame al 1-888-333-9952 para encontrar un soporte compatible.

2

¿De qué está hecha su pared?



Tabiques de yeso con montantes de madera ¡Perfecto!



Hormigón sólido o bloques de cemento - llame al 1-888-333-9952



¿No está seguro? Llame al 1-888-333-9952

3

¿Tiene todas las herramientas necesarias?

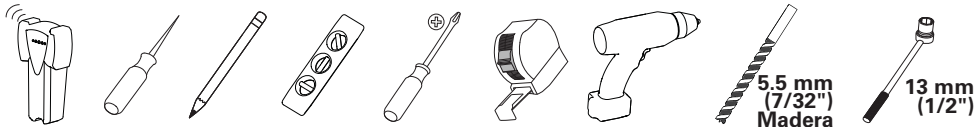

5.5 mm (7/32")
Madera

13 mm (1/2")

Opcional

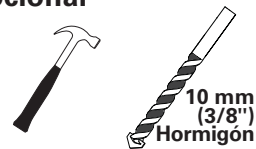

10 mm (3/8")
Hormigón

4

¿Listo para comenzar?

Lea estas instrucciones en su totalidad para estar seguro de sentirse cómodo con este fácil proceso de instalación. Consulte también el manual del usuario de su televisor para ver si existe algún requisito especial para instalar su televisor en la pared.

Si no entiende las instrucciones o si tiene dudas acerca de la seguridad de la instalación, del ensamblado o del uso del producto, contáctese con el servicio de atención al cliente al 1-888-333-9952.

⚠ PRECAUCIÓN: Evite lesiones y daños materiales.

- Este producto está diseñado para ser instalado en paredes con montantes de madera. NO lo instale en una pared de yeso únicamente.
- La pared debe soportar cinco veces el peso del televisor y del soporte juntos.
- No utilice este producto para ningún otro propósito que no sea el explícitamente especificado por el fabricante.
- El fabricante no se responsabiliza por ningún daño o lesión resultante del montaje incorrecto o del uso indebido.

Piezas y accesorios suministrados

⚠ ADVERTENCIA: Este producto contiene piezas pequeñas que, si fuesen tragadas, podrían producir asfixia.

Antes de iniciar el ensamblaje, compruebe que todas las piezas estén incluidas y en buenas condiciones. Si faltan piezas o alguna está dañada, no devuelva el artículo al distribuidor; póngase en contacto con el servicio de atención al cliente. Nunca utilice piezas deterioradas.



NOTA: No todos los accesorios incluidos deberán utilizarse.

PASO 1 Fijar la placa de sujeción al televisor

1-1 Mida el patrón de orificios del televisor

Mida en mm el ancho y el alto del patrón de orificios del televisor.

Anote las medidas:

Ancho _____ cm x Alto _____ cm

1-2 Arme la placa de sujeción del televisor

Determine qué configuración de placa de sujeción debe usar (A, B o C) según las medidas del patrón de orificios del televisor.

- A** Los patrones de orificios más pequeños solo requieren placa de sujeción **01**. No utilice las cuatro extensiones de la placa de sujeción **02** ni los ocho tornillos **03**.
- B** Ensamble las extensiones **02** de la placa de sujeción y la placa de sujeción **01** tal como se muestra en la ilustración. Fije colocando ocho tornillos **03** en los orificios de las esquinas que se muestran en la imagen.
- C** Ensamble las extensiones **02** de la placa de sujeción y la placa de sujeción **01** tal como se muestra en la ilustración. Fije colocando ocho tornillos **03** en los orificios de las esquinas que se muestran en la imagen.
- D** Ensamble las extensiones **02** de la placa de sujeción y la placa de sujeción **01** tal como se muestra en la ilustración. Fije colocando ocho tornillos **03** en los orificios de las esquinas que se muestran en la imagen.

1-3 Seleccione el diámetro de los tornillos para el televisor

Enrosque manualmente los tornillos en los encastres roscados del dorso del televisor a fin de determinar qué diámetro de tornillos (M5, M6 o M8) utilizar.

1-4 Seleccione el largo de los tornillos para el televisor

Si el dorso del televisor es plano, utilice los tornillos cortos.

Los espaciadores y los tornillos largos se proporcionan para:

- televisores con dorso irregular o redondeado
- televisores con orificios de montaje intercalados
- dejar un espacio adicional para cables

⚠ PRECAUCIÓN:

Verifique que el tornillo o la combinación de tornillo y espaciador enrosquen correctamente.

- Si el tornillo es demasiado corto, no sostendrá el televisor.
- Si es demasiado largo, dañará el televisor.

1-5 Fije la placa de sujeción

Posicione la placa de sujeción armada sobre el patrón de orificios del televisor y verifique que esté centrada y nivelada verticalmente. Instale las placas de sujeción usando la combinación que haya seleccionado para su televisor: tornillo corto y arandela o espaciador, o bien tornillo largo y arandela.

PASO 2A Fijar la placa mural - ÚNICAMENTE montantes de madera

⚠ **PRECAUCIÓN:** Evite lesiones y daños materiales.

- El yeso que recubre la pared no debe exceder los 16 mm (5/8").
 - Tamaño mínimo del montante de madera: común 51 mm x 102 mm (2" x 4"); nominal 38 mm x 89 mm (1 1/2" x 3 1/2").
1. Localice un montante. Busque los bordes del montante y marque el centro con un punzón o un clavo delgado, o bien utilice un detector de bordes de montantes.
 2. Ubique la plantilla de placa mural **15** a la altura deseada y alinee los orificios con la línea central de los montantes. Nivele la plantilla y fijela con cinta adhesiva en el lugar.
 3. Con una mecha de 5.5 mm (7/32") de diámetro, realice los orificios guía. Retire la plantilla de placa mural **15**.

⚠ **IMPORTANTE:** Asegúrese de perforar el centro del montante.

⚠ **IMPORTANTE:** Los orificios guía deben realizarse hasta una profundidad de 75 mm (3").

4. Instale la placa mural **16** usando tornillos tirafondo **18**. Ajuste los tornillos tirafondo **18** solamente hasta que las arandelas **17** queden firmes contra la placa mural **16**.

⚠ PRECAUCIÓN: El uso indebido podría reducir la capacidad de retención de los tornillos tirafondo. **NO ajuste en exceso los tornillos tirafondo.**

PASO 2B Fijar la placa mural a la pared - Opción para hormigón sólido o bloques de cemento

⚠ PRECAUCIÓN: Evite posibles lesiones personales y daños materiales.

- Instale la placa mural **16** directamente sobre la superficie de hormigón.
- Espesor mínimo del hormigón: 203mm (8 pulgadas)
- Tamaño mínimo del bloque de cemento: 203 x 203 x 406 mm (8 x 8 x 16 pulgadas)
- Espacio horizontal mínimo entre los elementos de sujeción: 406 mm (16 pulgadas)

1. Coloque la plantilla de la placa mural **15** en la pared a la altura que desee. Nivele la plantilla de la placa mural y marque la ubicación de los orificios.
2. Realice los orificios guía con una mecha para mampostería de 10 mm (3/8") de diámetro.

! IMPORTANTE: Los orificios guía deben realizarse hasta una profundidad de 75 mm (3"). Nunca perforo el cemento que une los bloques.

3. Retire la plantilla de la placa mural **15** e introduzca cuatro anclajes (Fischer UX 10 x 60 - incluidos en el [Kit de instalación en hormigón CMK1*](#)).

⚠ PRECAUCIÓN: Cerciórese de que los anclajes queden nivelados respecto de la superficie de hormigón.

4. Instale el módulo de la placa mural **16** usando cuatro tornillos tirafondo y cuatro arandelas (utilizar únicamente los tornillos tirafondo y las arandelas del Kit de instalación en hormigón CMK1*). Ajuste los tornillos tirafondo solamente hasta que queden firmes contra la placa mural.

⚠ PRECAUCIÓN: El uso indebido podría reducir la capacidad de retención de los tornillos. **NO ajuste en exceso los tornillos tirafondo.**

* Comuníquese con el servicio de atención al cliente al 1-888-333-9952 para solicitar que le enviemos el [Kit de instalación en hormigón](#).

El Kit de instalación en hormigón CMK1 no está incluido (Ver página 6) Comuníquese con el servicio de atención al cliente al 1-888-333-9952 para solicitar que le enviemos los elementos de sujeción adicionales.

PASO 3 Colgar el televisor en la placa mural



¡ELEMENTO PESADO! Es posible que necesite ayuda en este paso.

1. Para colgar el brazo **19** de la placa mural **16**, primero enganche el soporte superior y luego apoye el brazo **19** en su lugar.
2. Instale los tornillos de seguridad **21** para fijar el brazo a la placa mural **16**.
3. Pliegue la primera sección del brazo **19** contra la placa mural **16** para dar mayor estabilidad.
4. Para colgar la placa de sujeción del televisor **01** del brazo **19**, primero enganche el soporte superior y luego apoye el televisor en su lugar.
5. Fije la placa de sujeción del televisor **01** al brazo **19** con el tornillo de seguridad **20**.

! **IMPORTANTE:** Este tornillo de seguridad **20** debe instalarse para fijar la placa de sujeción del televisor **01** al brazo **01**.

Organización de cables

Los cables pueden pasarse por los canales para cables que se encuentran en la parte superior e inferior del brazo **19** y fijarse al brazo con precintos plásticos **22** para un aspecto más prolijo.

Ajustes del televisor

AJUSTE DE LA INCLINACIÓN

El televisor debe acomodarse fácilmente al moverlo, y luego quedar en su lugar.

Si el televisor está demasiado suelto o demasiado ajustado, ajuste la perilla de tensión de inclinación manualmente.



NOTA: Una vez que el televisor esté en su lugar, ajuste la perilla de tensión de inclinación para evitar movimientos indeseados.

AJUSTE DEL NIVEL

Para modificar la nivelación de su televisor, afloje el tornillo de seguridad **20**, nivele su televisor, y luego ajuste el tornillo de seguridad **20**.

¡ IMPORTANTE: Este tornillo de seguridad **20** debe instalarse para fijar el televisor al brazo **19**.

EXTRACCIÓN DEL TELEVISOR



¡ELEMENTO PESADO!
Es posible que necesite ayuda en este paso.

Para extraer el televisor del módulo del brazo **19**, desconecte todos los cables y luego revierta el procedimiento descrito en el **PASO 3**.

Descripción

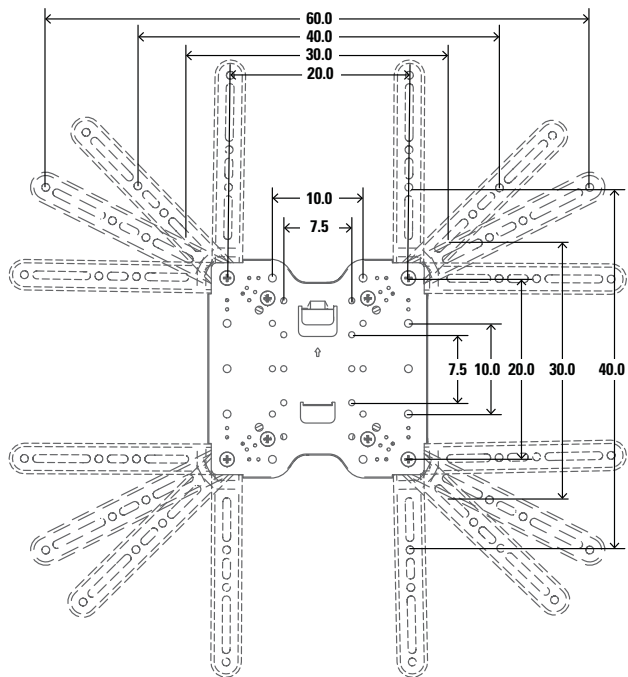

La placa de sujeción puede configurarse para adecuarse a televisores con patrones de orificios de 7.5 x 7.5 cm hasta 40.0 x 40.0 cm.

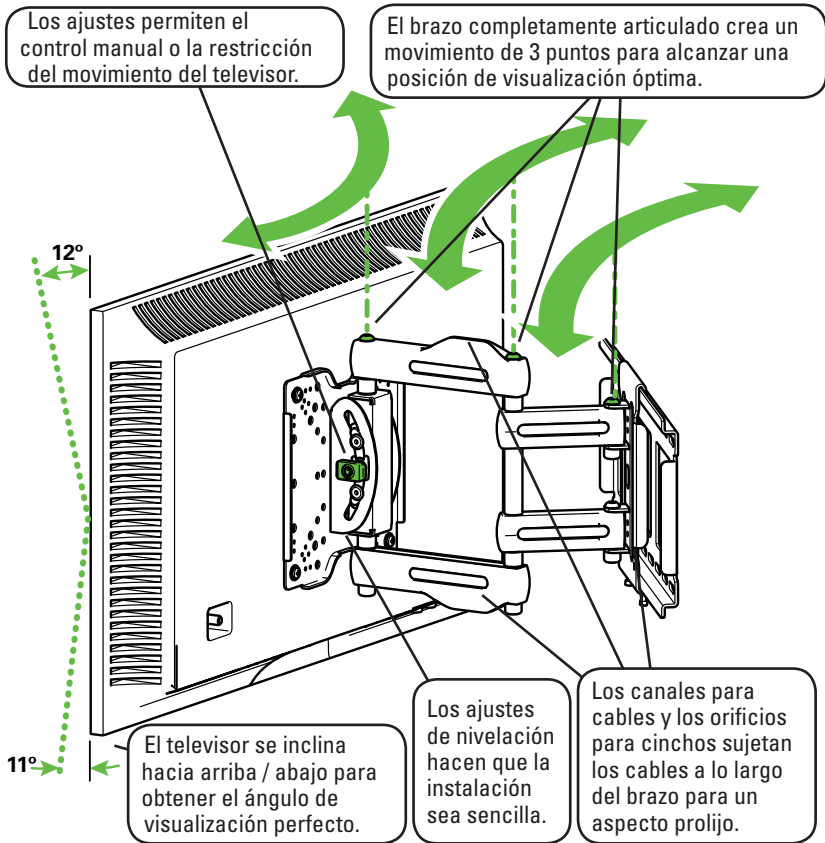



Thank you for choosing Sanus Vuepoint! Please take a moment to let us know how we did:



Call us: 1-888-333-9952



Email us: info@sanus.com



Leave a review: vuepoint.sanus.com

Milestone AV Technologies and its affiliated corporations and subsidiaries (collectively, "Milestone"), intend to make this manual accurate and complete. However, Milestone makes no claim that the information contained herein covers all details, conditions, or variations. Nor does it provide for every possible contingency in connection with the installation or use of this product. The information contained in this document is subject to change without notice or obligation of any kind. Milestone makes no representation of warranty, expressed or implied, regarding the information contained herein. Milestone assumes no responsibility for accuracy, completeness or sufficiency of the information contained in this document.

©2014 Milestone AV Technologies. All rights reserved. Sanus is a division of Milestone.
All other brand names or marks are used for identification purposes and are trademarks of their respective owners.