

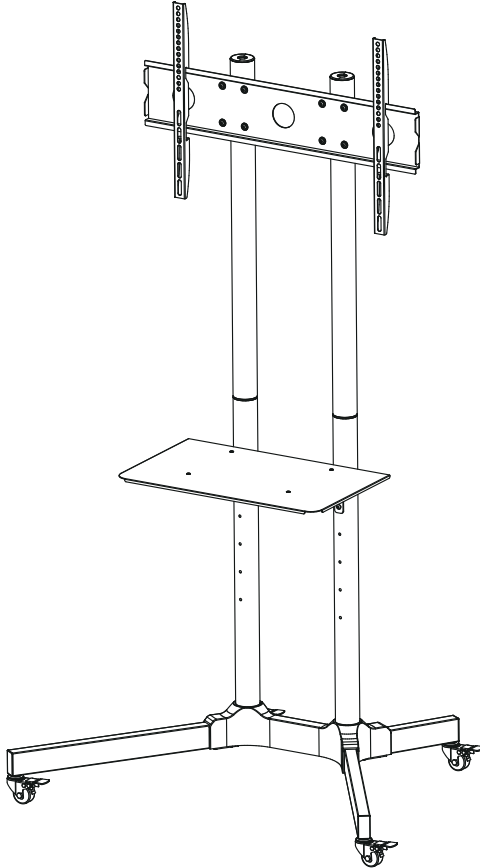

PERLESMITH

# TV Trolley Stand Instruction Manual

V2.0



**MODEL: PSTVMC01**

For any parts enquiries, please contact AV Supply Group as below:

New Zealand P 64 9 274 9172

Asutralia P 61 3 9071 4585



E [info@avsupply.co.nz](mailto:info@avsupply.co.nz)



E [info@avsupplygroup.com.au](mailto:info@avsupplygroup.com.au)

## Tools Required:

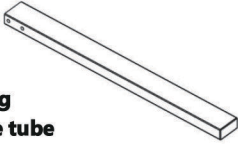
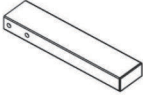
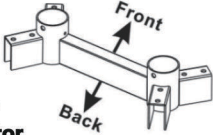
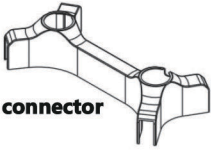
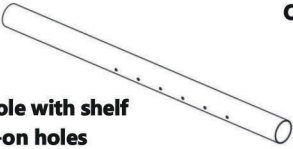
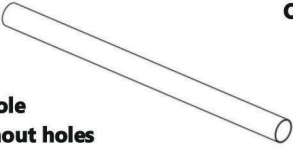

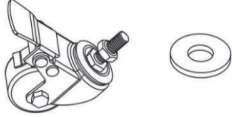
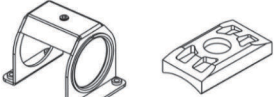
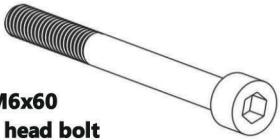
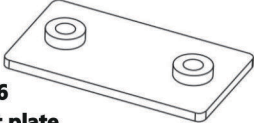

Phillips screwdriver





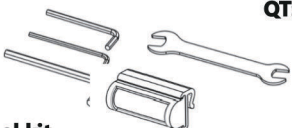
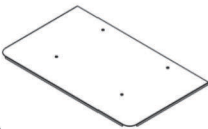
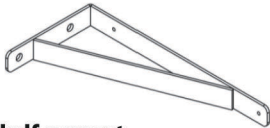

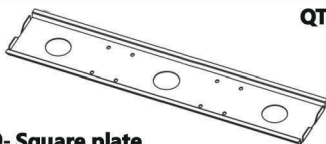
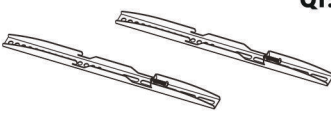
# Package Contents

 <b>1- Long square tube</b>	<b>QT: 2</b>
 <b>2- Short square tube</b>	<b>QT: 2</b>
 <b>3- Tube connector</b>	<b>QT: 1</b>
 <b>4- Tube connector cover</b>	<b>QT: 1</b>
 <b>5- Pole with shelf add-on holes</b>	<b>QT: 2</b>
 <b>6- Pole without holes</b>	<b>QT: 2</b>
 <b>7- Pole connector</b>	<b>QT: 2</b>

 <b>8- Pole cover</b>	<b>QT: 4</b>
 <b>9- Wheel &amp; washer</b>	<b>QT: 4</b>
 <b>10- Square plate connector &amp; rubber pad</b>	<b>QT: 2</b>
 <b>11- M6x60 allen head bolt</b>	<b>QT: 8</b>
 <b>12- M6 socket plate</b>	<b>QT: 4</b>
 <b>13- M6x10 allen head bolt</b>	<b>QT: 14</b>
 <b>14- M5x6 grub screw</b>	<b>QT: 2</b>

# Package Contents (Continued)

	QT: 1
<b>15- Tool kit</b>	
	QT: 1
<b>16- Shelf</b>	
	QT: 2
<b>17- Shelf support</b>	
	QT: 4
<b>18- M4x6 countersink bolt</b>	
	QT: 1
<b>19- Square plate</b>	
	QT: 1
<b>20- TV arm set</b>	
	QT: 4
<b>21- M4x12 bolt</b> <b>M4x30 bolt</b>	

	QT: 4
<b>22- M6x20 bolt</b> <b>M6x35 bolt</b>	
	QT: 4
<b>23- M8x20 bolt</b> <b>M8x35 bolt</b> <b>M8x45 bolt</b>	
	QT: 4
<b>24- M4 washer</b>	
	QT: 12
<b>25- M6 washer</b>	
	QT: 4
<b>26- M8 washer</b>	
	QT: 4
<b>27- M4 spacer</b> <b>M6/M8 spacer (20mm)</b>	
	QT: 8
<b>28- M6/M8 spacer (5mm)</b>	

## Step 1: Assembly Steps

Attach wheels and washers (9) to the long and short square tubing (1,2) using the provided wrench (15).

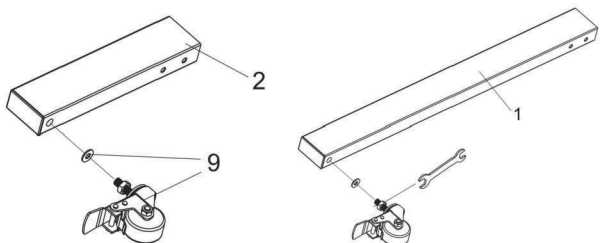

## Step 2:

Attach the square tubing (1,2) to the tube connector (3) using M6x60 Allen head bolt (11) and the M6 socket plate (12).

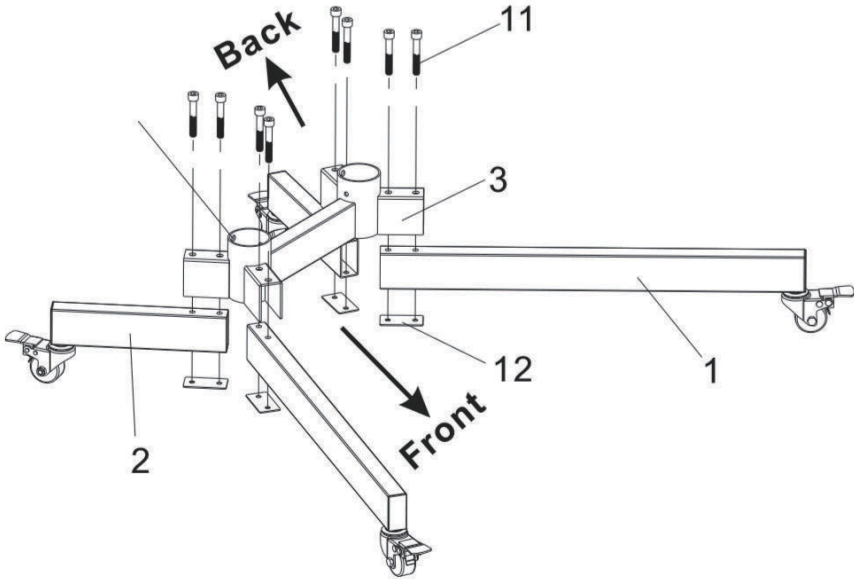

## Step 3:

Attach the base poles (5) to the tube connector (3) using M6x10 bolts (13) in the back and M5x6 grub screws (14) in the sides. Thread on the pole connectors (7) to the tops of each base pole (5). Be cautious of the connector threads which may have sharp edges.

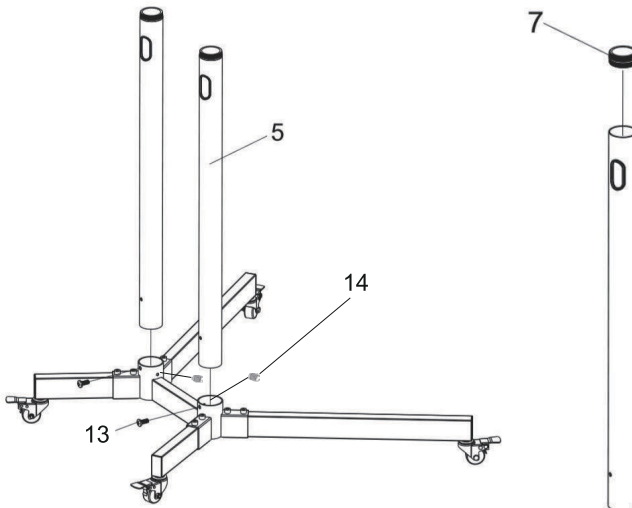

## Step 4:

**4a:** Slide the tube connector cover (4) over the base poles (5) and fit over the tube connector (3).

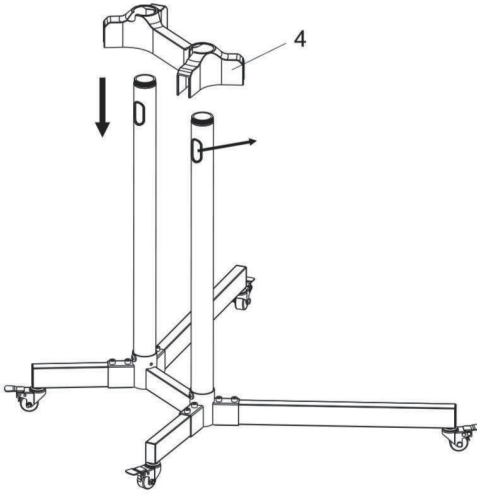

**4b:** Thread the top poles (6) to the pole connectors (7) and insert the pole covers (8) into the top.

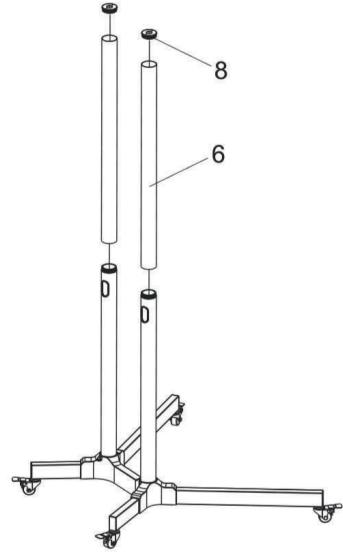

## Step 5:

**5a:** Slide the square plate connectors and rubber pads (10) over the top of the poles (6) and tighten the grub screw using tool kit (15).

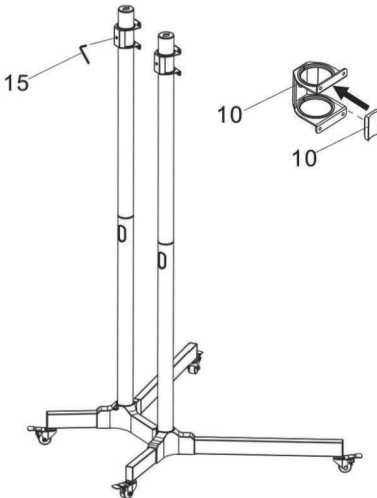

**5b:** Attach the square plate (19) to the square plate connectors (10) with 8 M6x10 Allen head bolts (13) and 8 M6 washers (25) using tool kit

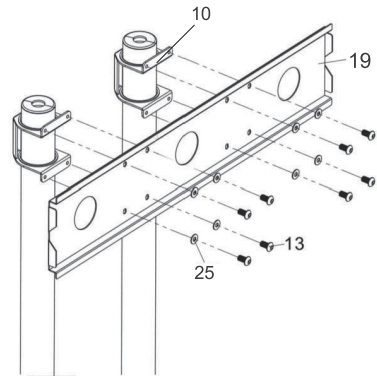

## Step 6:

**6a:** Clip bubble level from tool kit (15) onto the square plate (19). Adjust the level of the square plate (19) by loosening the grub screw in the back of the square plate connector (10) using tool kit (15). Tighten grub screws again once you've reached desired height and level.

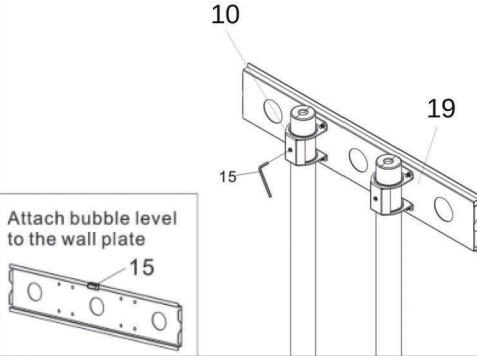

**6b:** Secure TV arm set (20) to the back of your television using bolts 21-23 and washers 24-26, depending on the size of the mounting holes on the television. For curved or recessed TVs, a spacer (27,28) may be required.

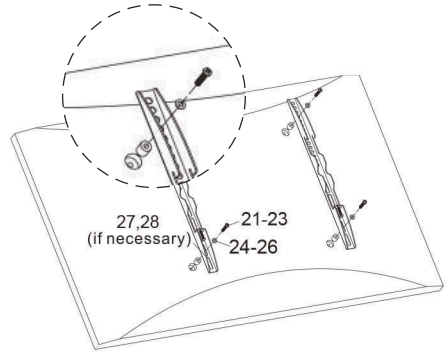

## Step 7:

Attach the TV arm set (20) to the square plate (19). Tighten the safety bolts on the bottom of the TV arm set (20) to secure the television to the stand.

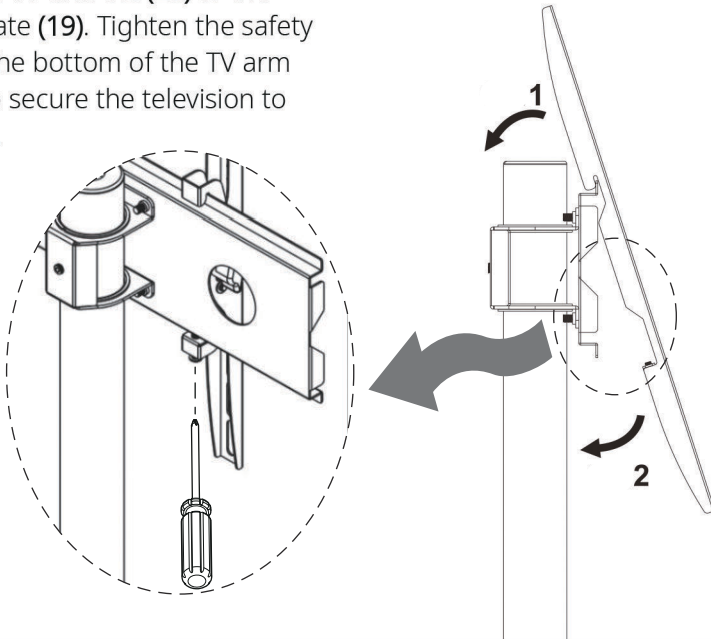

## Step 8:

**8a:** If additional leveling and height adjustment is required after television is attached, repeat step 6.

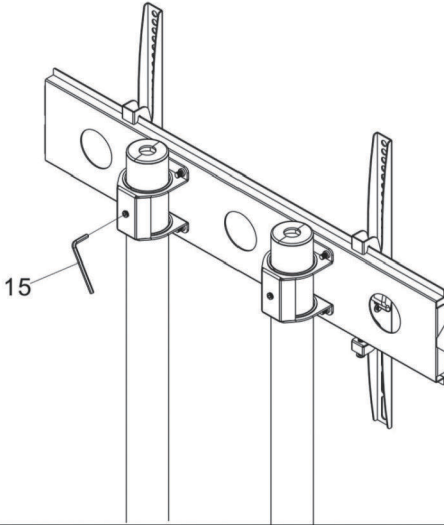

**8b:** For wire management, cables can be run through the tops of the pole covers (8) and down through the poles.

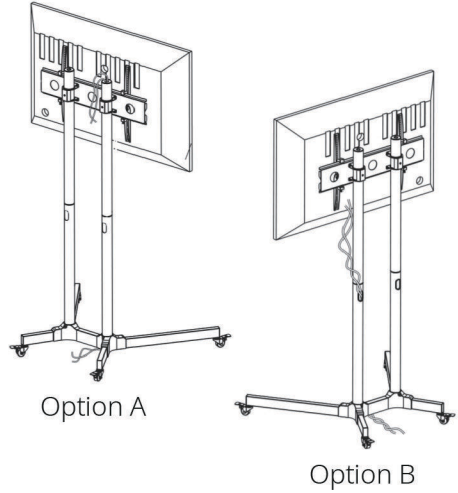

## Step 9:

To attach the shelf (16), first attach the shelf supports (17) to the bottom poles (5) using 4 M6x10 Allen head bolts (13). Once secured, attach the shelf (16) to the supports (17) using 4 M4x6 countersink bolts (18).

